

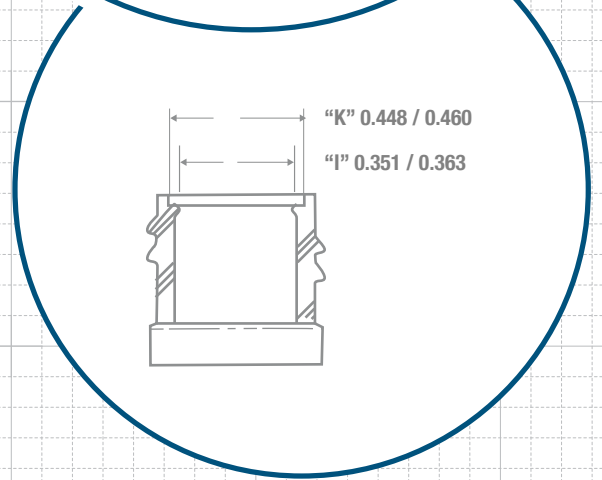

# NECK & THREAD DETAIL

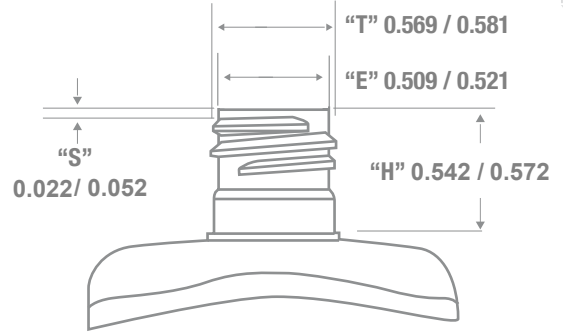

## FRONT VIEW

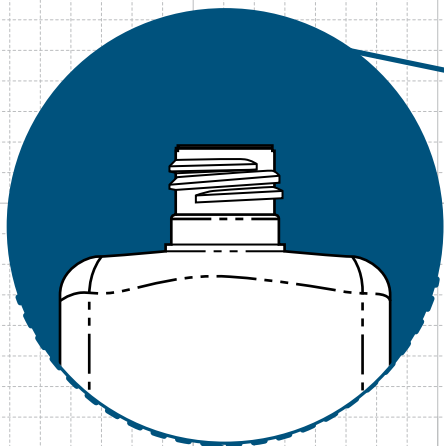
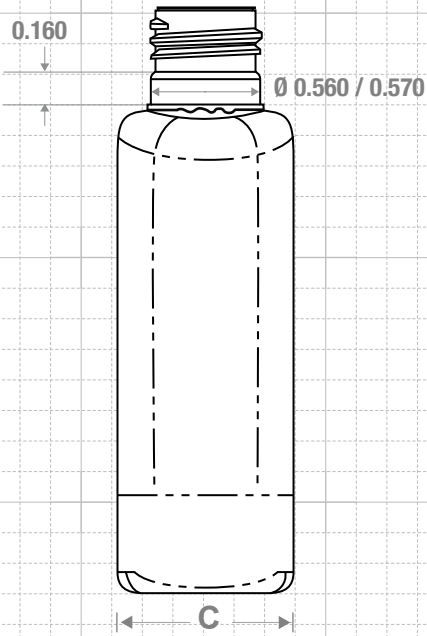
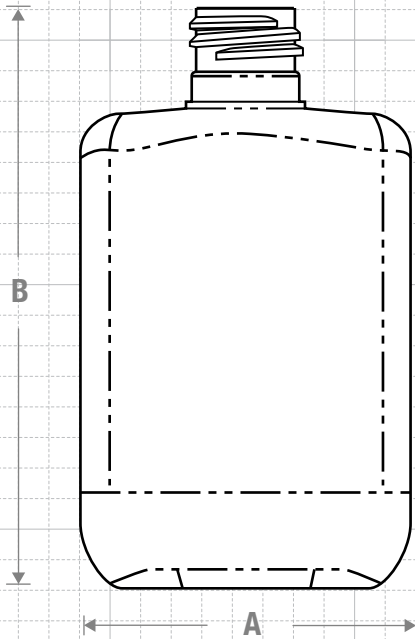

## SIDE VIEW

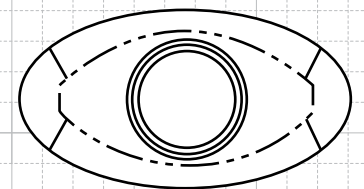
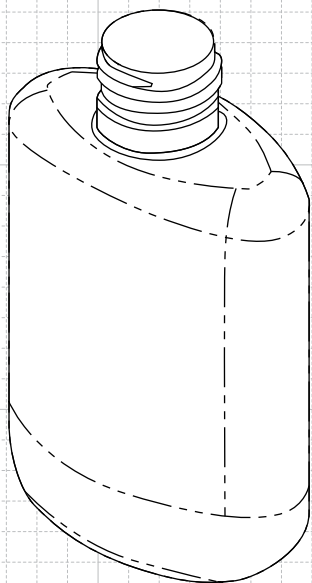

## TOP VIEW



## DROPPER TIP CAP

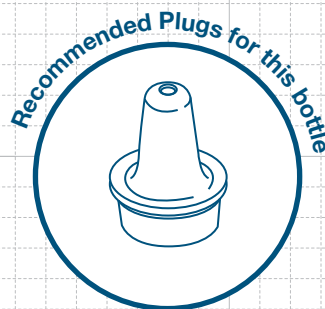

## SNAP FIT

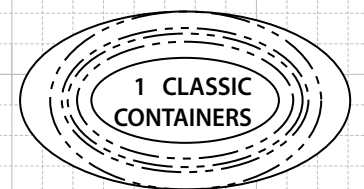

## BOTTOM VIEW



**CLASSIC CONTAINERS INC**  
 1700 S. Hellman Ave.  
 Ontario, CA 91761  
 Phone: 909-930-3610  
 e-mail: info@classiccontainers.com  
 www.classiccontainers.com

Drawing:  
**1 1/4 oz Drug Oval 15/415 Snap Fit**

Stock Code:  
**0114002101500SF**

Manufacturing Process:  
**Extrusion Blow Molding**

Overflow Capacity:  
**41.3 - 44.2 ml (1.40 - 1.50 oz)**

Gram Weight:  
**6 ± 1**

Neck Finish:  
**15/415 Snap Fit**

Base Width (A): Base Deep (C)  
**1.725 ± 0.050 0.925 ± 0.050**

Overall Height (B):  
**3.080 ± 0.050**

Max Print Area (Height):  
**1.750"**

Max Print Area (Width):  
**1.250"**

Case Pack: **1300**

Case Weight (lb): **19.3 ± 2.9**

Cases Per Pallet: **25**

Box Dimensions:  
**23 5/8 x 15 9/16 x 17**

Stock Material:



