

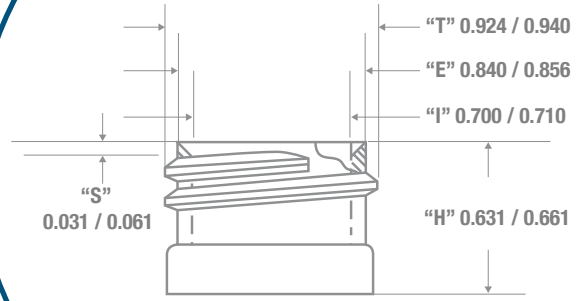

NECK & THREAD DETAIL

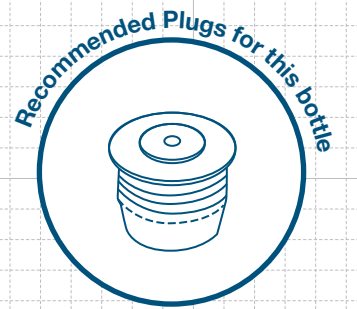

FRONT VIEW

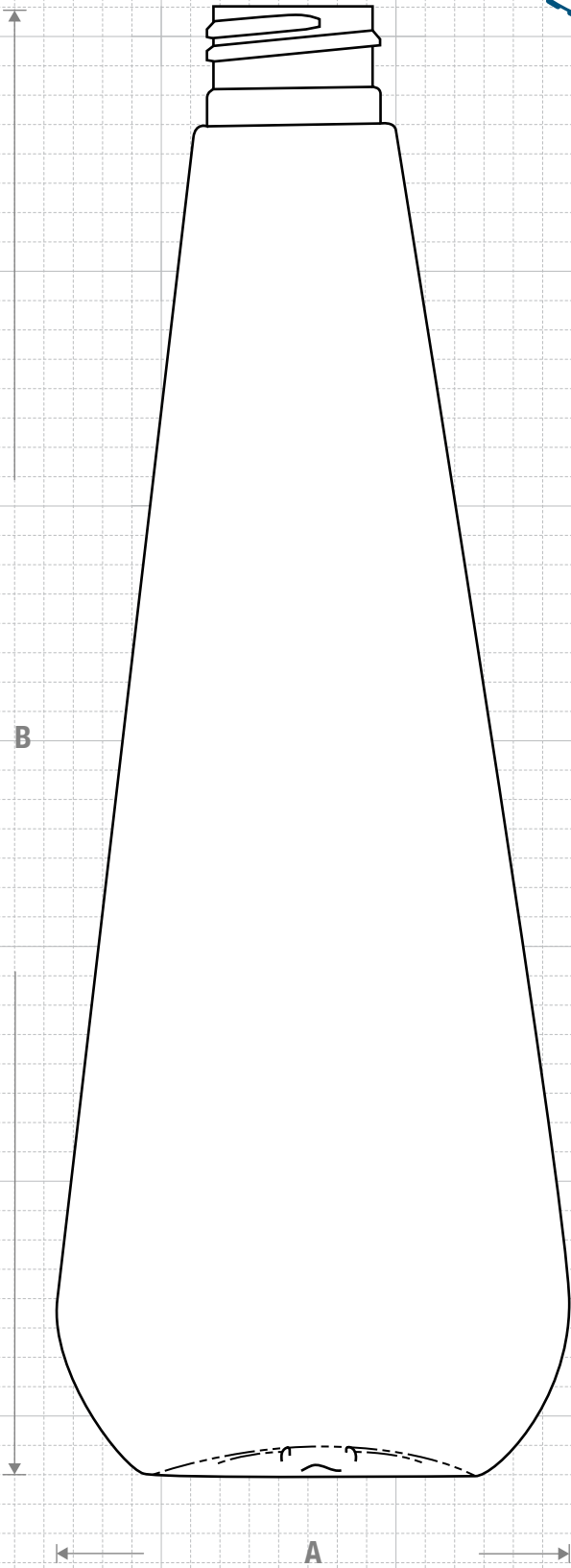

FRICION FIT

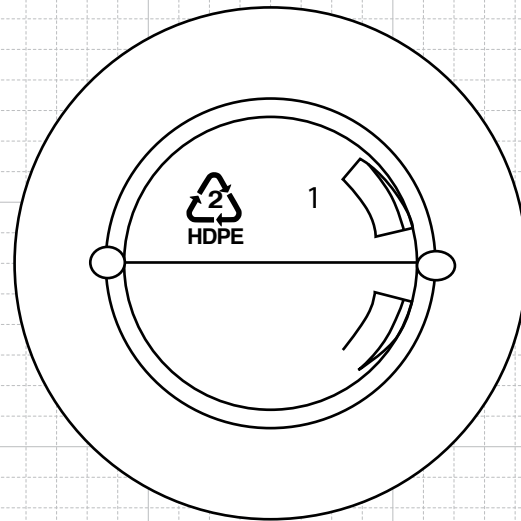

BOTTOM VIEW



CLASSIC CONTAINERS INC
 1700 S. Hellman Ave.
 Ontario, CA 91761
 Phone: 909-930-3610
 e-mail: info@classiccontainers.com
 www.classiccontainers.com

Drawing:
12 oz Pin Drop 24/410

Gram Weight:
29.0 ± 2

Max Print Area (Height):
3.500"/2.000"

Cases Per Pallet: **16**

Stock Code:
001201390240000

Neck Finish:
24/410

Max Print Area (Width):
4.125"

Box Dimensions:
24 7/16 x 18 1/2 x 23

Manufacturing Process:
Extrusion Blow Molding

Base Width (A):
2.750 ± 0.050

Case Pack: **288**

Stock Material:



Overflow Capacity:
366 -384 ml (12.4 - 13.0 oz)

Overall Height (B):
8.037 ± 0.050

Case Weight (lb): **21.3 ± 1.3**

Rev #3 06/2016

Drawing not exactly to size.

