

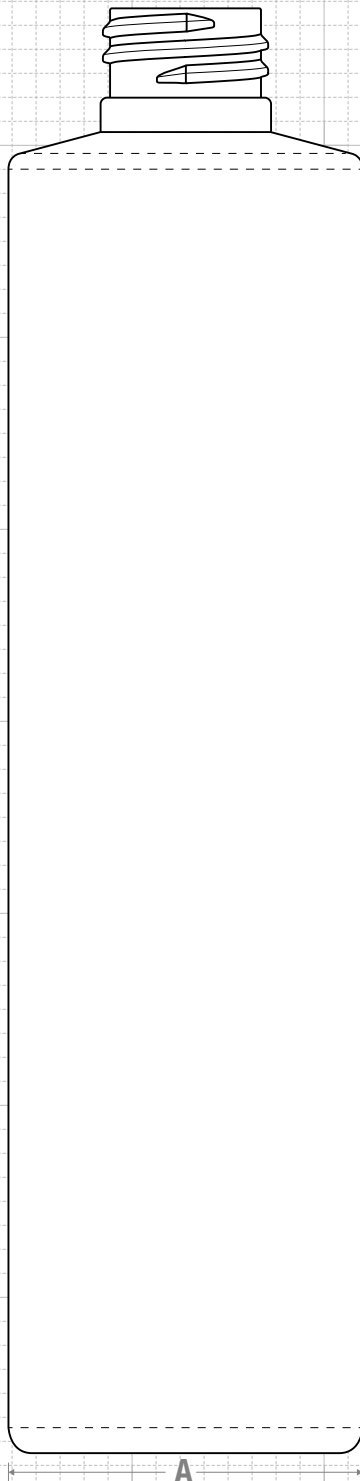

### FRONT VIEW



Drawing:  
**300ml Cylinder Round**  
**24/410**

Stock Code:  
**030000010241700**

Manufacturing Process:  
**Stretch Molding**

Overflow Capacity:  
**306.8 - 324.5ml (10.4 - 11 oz)**

Gram Weight:  
**25 ± 1**

Neck Finish:  
**24/410**

Base Width (A):  
**1.950 ± 0.050**

Overall Height (B):  
**7.525 ± 0.050**

Max Print Area (Height):  
**6.000"**

Max Print Area (Width):  
**5.950"**

Case Pack: **396**

Case Weight (lb): **24.7 ± 0.9**

Cases Per Pallet: **16**

Box Dimensions:  
**24 x 18 x 23**

Stock Material:



**CLASSIC CONTAINERS INC**  
1700 S. Hellman Ave.  
Ontario, CA 91761  
Phone: 909-930-3610  
e-mail: info@classiccontainers.com  
[www.classiccontainers.com](http://www.classiccontainers.com)

### NECK & THREAD DETAIL

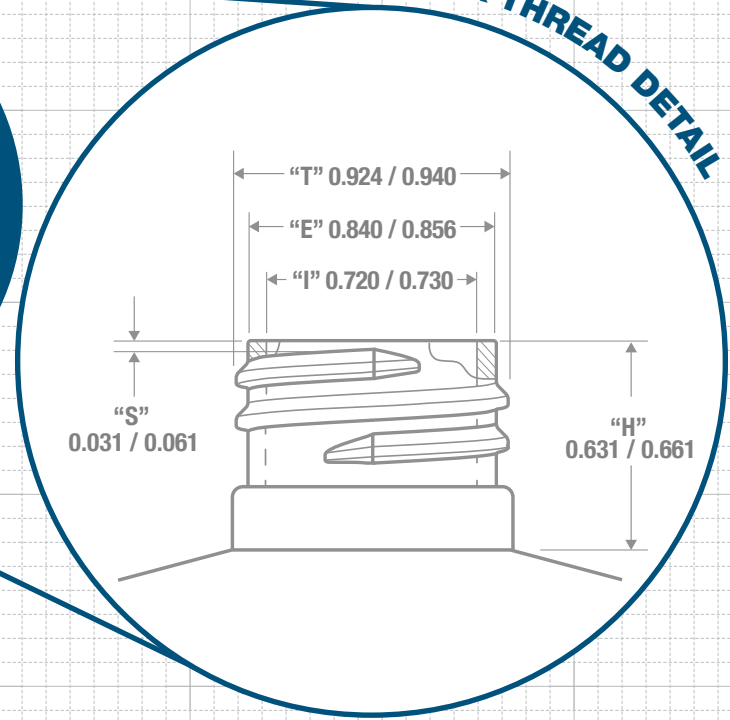
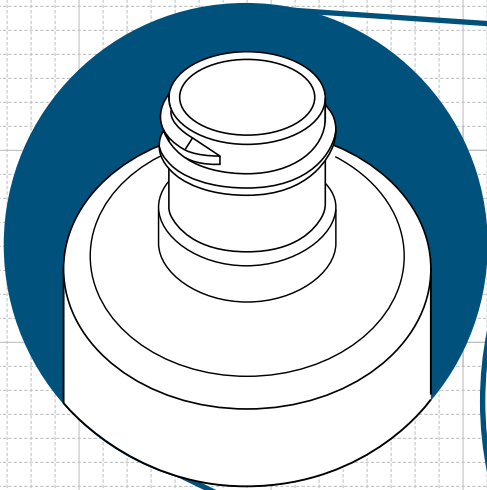

### TOP VIEW

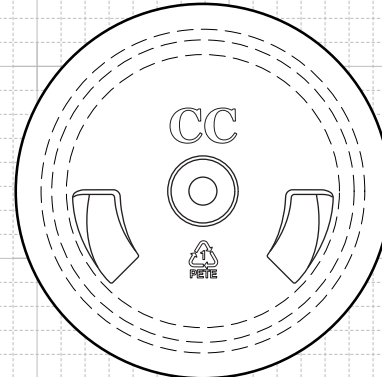
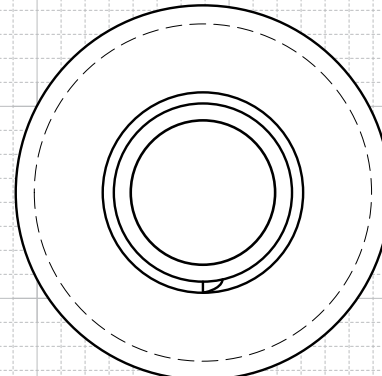

### BOTTOM VIEW

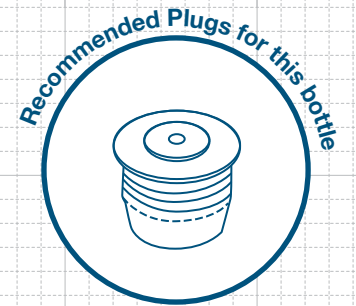

### FRICITION FIT

# PRINTING SPECIFICATIONS: 300 ml (10 oz) CYLINDER ROUND

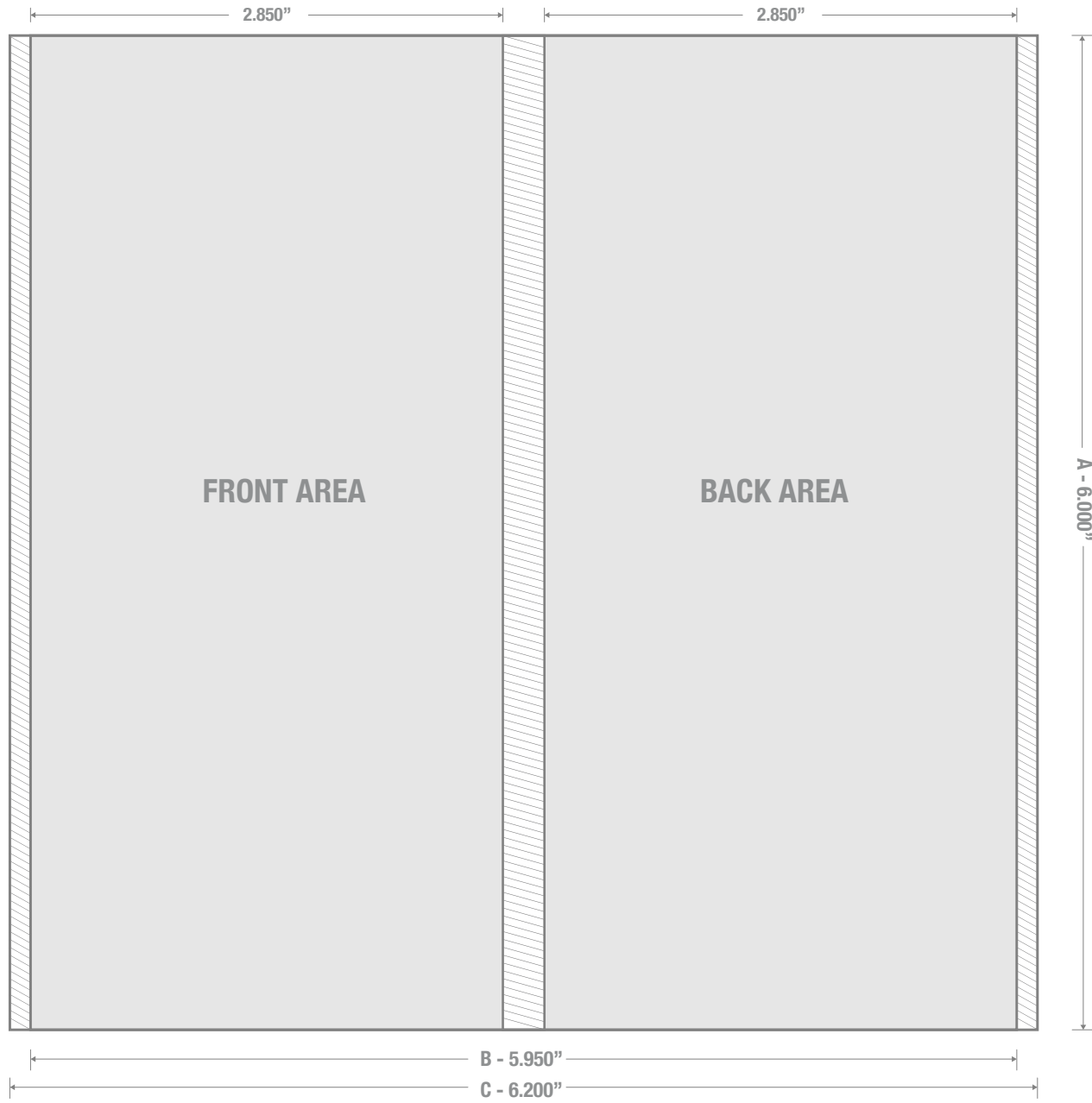

1700 S Hellman Ave, Ontario, California 91761  
Phone: (909) 930-3610 | Fax: (909) 930-3640  
e-mail: [info@classiccontainers.com](mailto:info@classiccontainers.com)  
[www.classiccontainers.com](http://www.classiccontainers.com)

**A - Total Height.**  
**B - Max. Decorating Area.**  
**C - Total bottle circumference.**  
▨ - Unprintable area.