



Drawing:  
**6 oz Classic Oval 24/415**

Stock Code:  
**000600230250000**

Manufacturing Process:  
**Extrusion Blow Molding**

Overflow Capacity:  
**195 - 207 ml (6.6 - 7.0 oz)**

Gram Weight:  
**16.5 ± 1**

Neck Finish:  
**24/415**

Base Width (A): Base Depth (C)  
**2.240 ± 0.050 1.280 ± 0.050**

Overall Height (B):  
**6.230 ± 0.050**

Max Print Area (Height):  
**4.000"**

Max Print Area (Width):  
**1.625"**

Case Pack: **516**

Case Weight (lb): **21.7 ± 1.1**

Cases Per Pallet: **16**

Box Dimensions:  
**24 7/16 x 18 1/2 x 23**

Stock Material:



**CLASSIC CONTAINERS INC**  
1700 S. Hellman Ave.  
Ontario, CA 91761  
Phone: 909-930-3610  
e-mail: info@classiccontainers.com  
www.classiccontainers.com

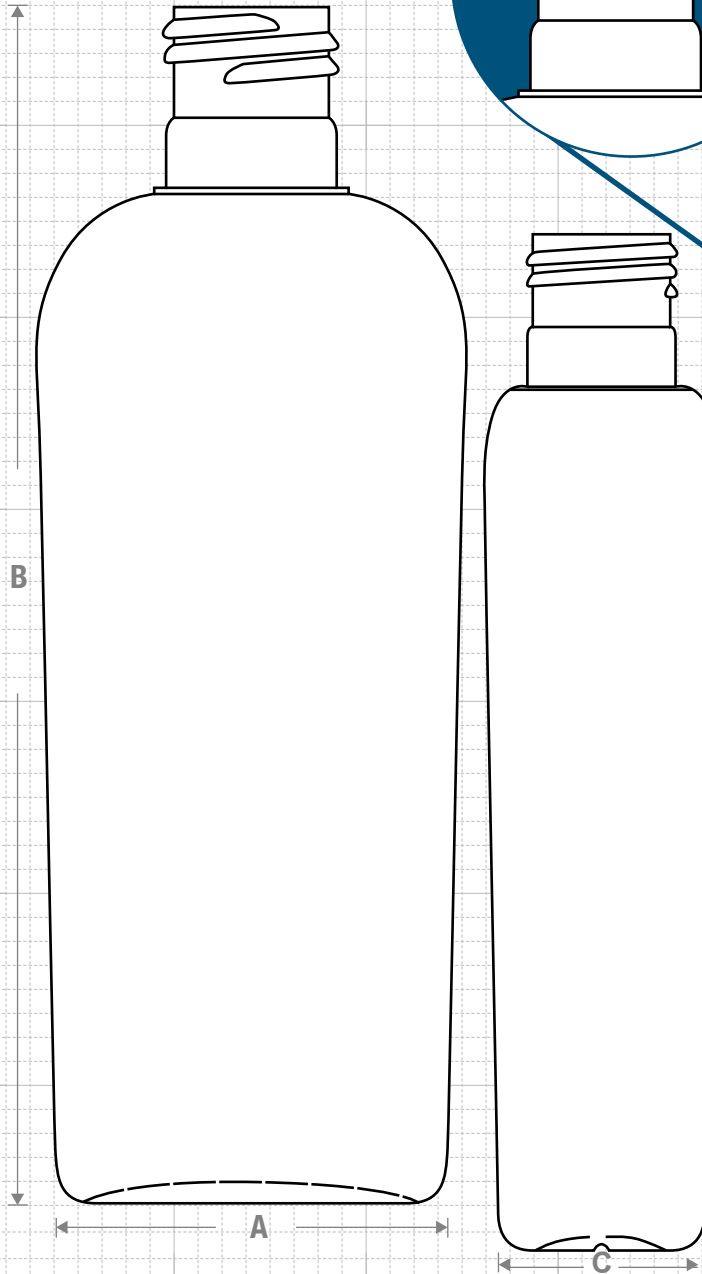

**FRONT VIEW**

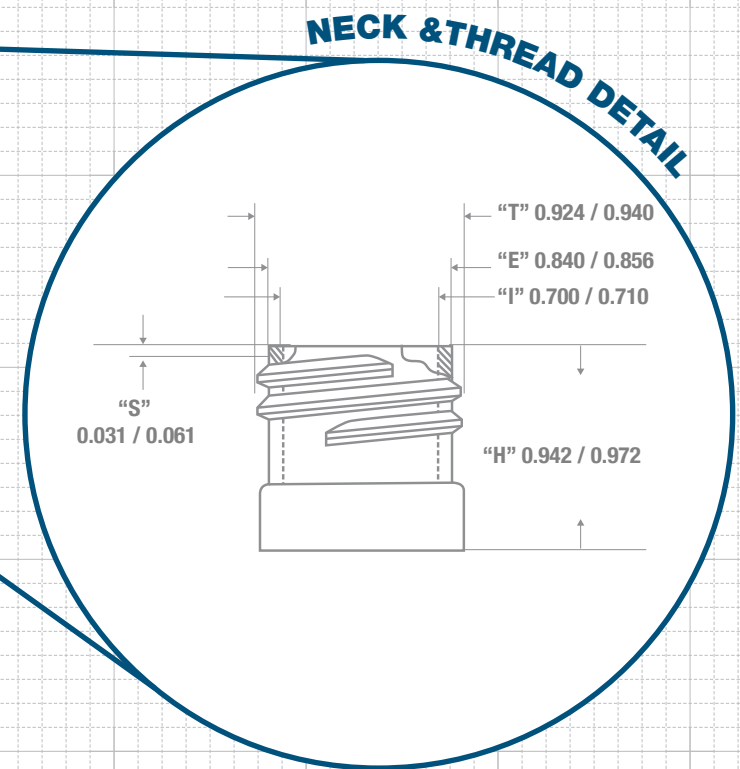
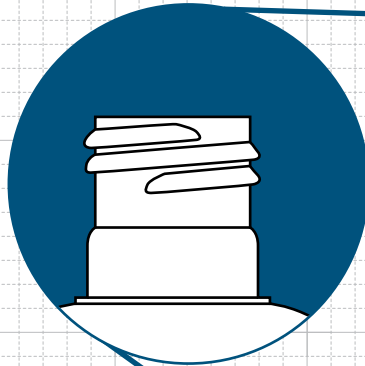

**NECK & THREAD DETAIL**

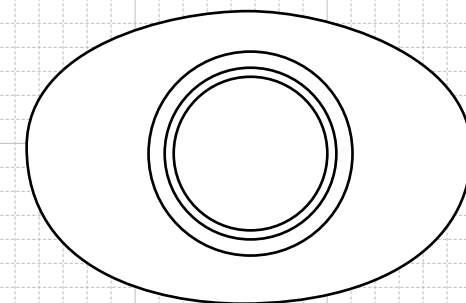

**TOP VIEW**

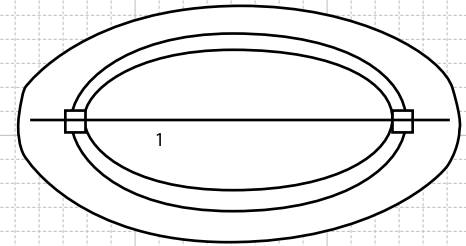

**BOTTOM VIEW**

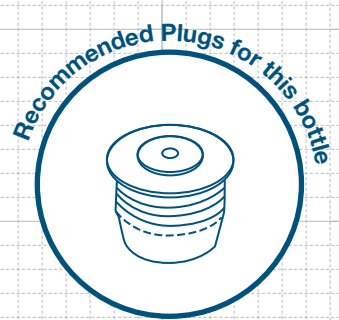

**FRICION FIT**

- 2 HDPE
- 4 LDPE
- 5 PP
- OTHER

PRINTING SPECIFICATIONS: 6 oz CLASSIC OVAL 24/415

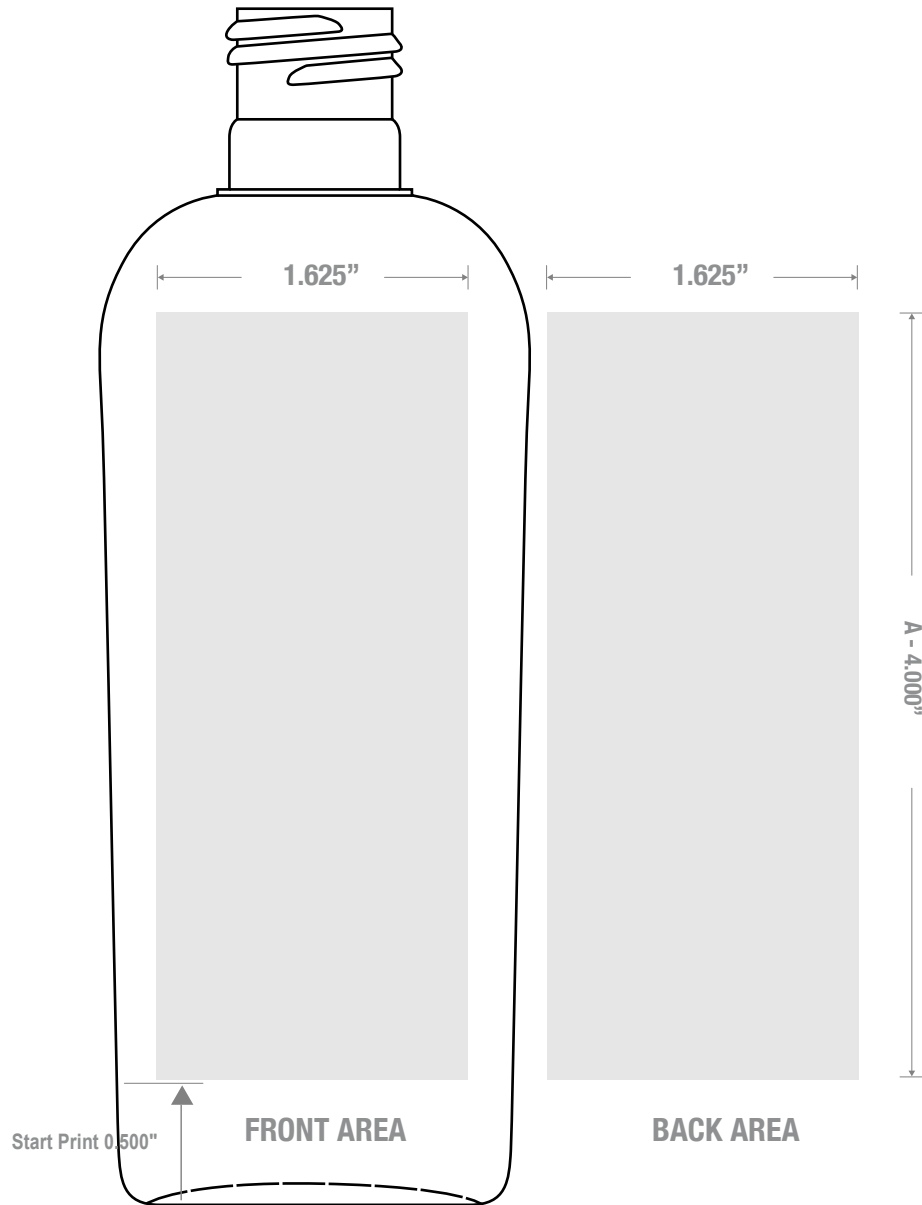

1700 S Hellman Ave, Ontario, California 91761  
Phone: (909) 930-3610 | Fax: (909) 930-3640  
e-mail: [info@classiccontainers.com](mailto:info@classiccontainers.com)  
[www.classiccontainers.com](http://www.classiccontainers.com)

A - Total Height.  
B - Max. Decorating Area.

# LABELING SPECIFICATIONS: 6 oz CLASSIC OVAL 24/415



1700 S Hellman Ave, Ontario, California 91761  
Phone: (909) 930-3610 | Fax: (909) 930-3640  
e-mail: [info@classiccontainers.com](mailto:info@classiccontainers.com)  
[www.classiccontainers.com](http://www.classiccontainers.com)

**A - Total Height.**  
**B - Max. Decorating Area.**