



Drawing:
500 ml Boston Round 24/415

Stock Code:
050000060251700

Manufacturing Process:
Stretch Blow Molding

Overflow Capacity:
522 - 546 ml (17.7 - 18.5 oz)

Gram Weight:
31 ± 1

Neck Finish:
24/415

Base Width (A):
2.927 ± 0.050

Overall Height (B):
6.250 ± 0.050

Max Print Area (Height):
3.725"

Max Print Area (Width):
9.028"

Case Pack: 211

Case Weight (lb): 17.3 ± 0.5

Cases Per Pallet: 16

Box Dimensions:
24 7/16 x 18 1/2 x 23

Stock Material:



CLASSIC CONTAINERS INC
1700 S. Hellman Ave.
Ontario, CA 91761
Phone: 909-930-3610
e-mail: info@classiccontainers.com
www.classiccontainers.com

FRONT VIEW

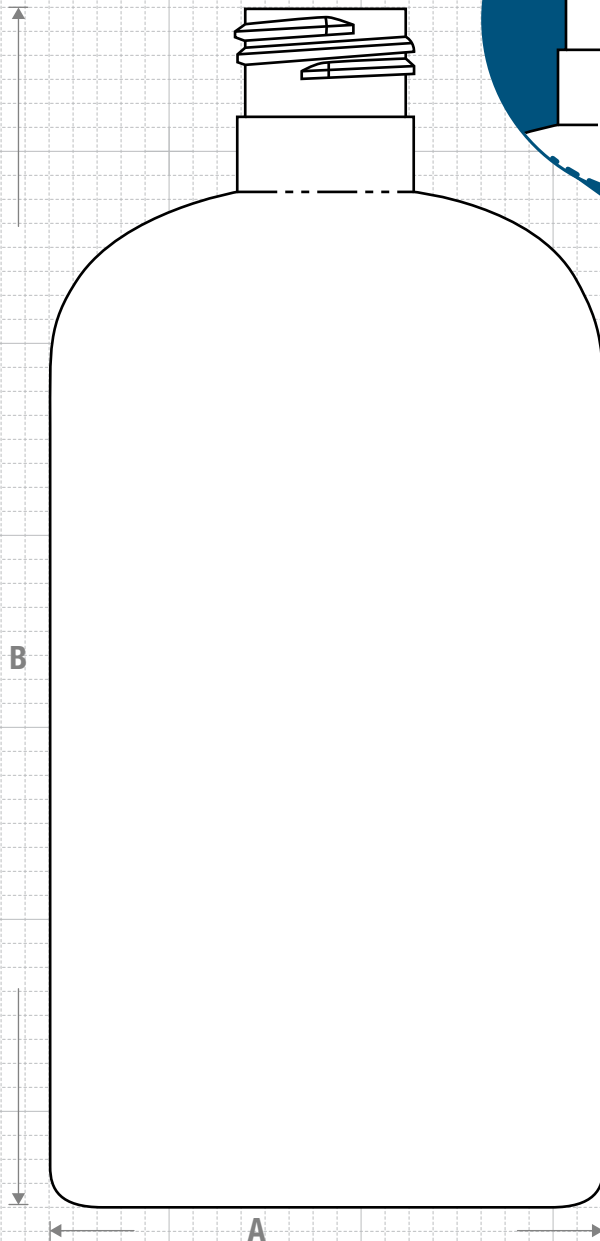

NECK & THREAD DETAIL

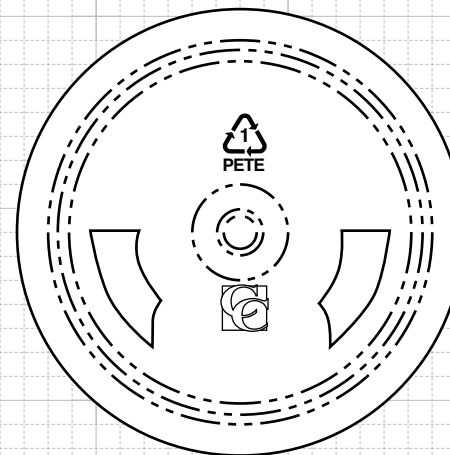
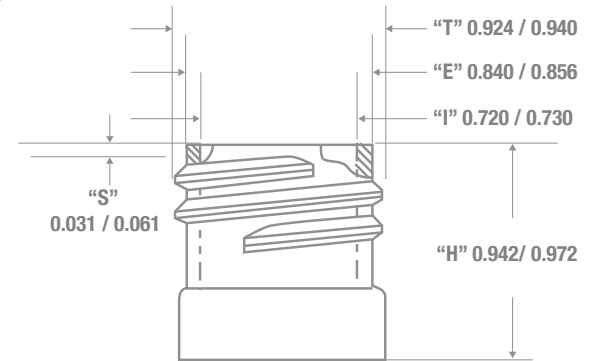

BOTTOM VIEW

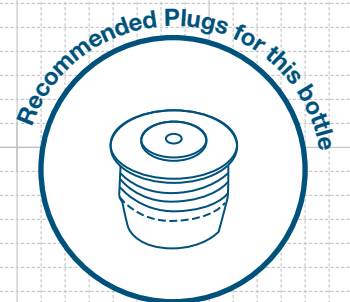

FRICITION FIT

PRINTING SPECIFICATIONS: 500 ml BOSTON ROUND 24/415

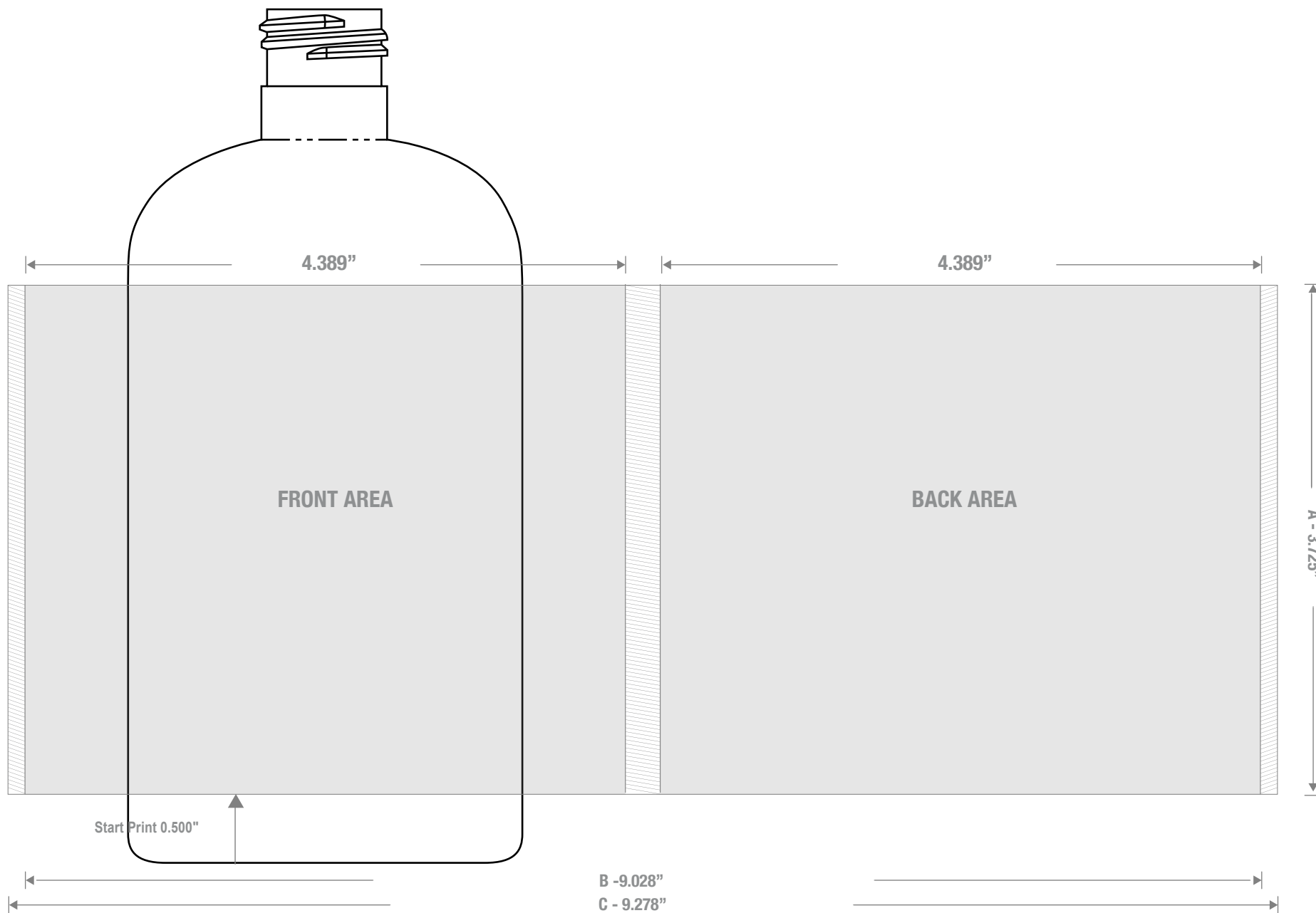

1700 S Hellman Ave, Ontario, California 91761
 Phone: (909) 930-3610 | Fax: (909) 930-3640
 e-mail: info@classiccontainers.com
www.classiccontainers.com

A - Total Height.
B - Max. Decorating Area.
C - Total bottle circumference.
 [Hatched Box] - Unprintable area.