



Drawing:  
500 ml Boston Round 24/410

Stock Code:  
050000060241700

Manufacturing Process:  
Stretch Blow Molding

Overflow Capacity:  
519 - 543 ml (17.6 - 18.4 oz)

Gram Weight:  
31 ± 1

Neck Finish:  
24/410

Base Width (A):  
2.927 ± 0.050

Overall Height (B):  
5.950 ± 0.050

Max Print Area (Height):  
3.725"

Max Print Area (Width):  
9.028"

Case Pack: 211

Case Weight (lb): 17.3 ± 0.5

Cases Per Pallet: 16

Box Dimensions:  
24 7/16 x 18 1/2 x 23

Stock Material:



**CLASSIC CONTAINERS INC**  
1700 S. Hellman Ave.  
Ontario, CA 91761  
Phone: 909-930-3610  
e-mail: info@classiccontainers.com  
www.classiccontainers.com

**FRONT VIEW**

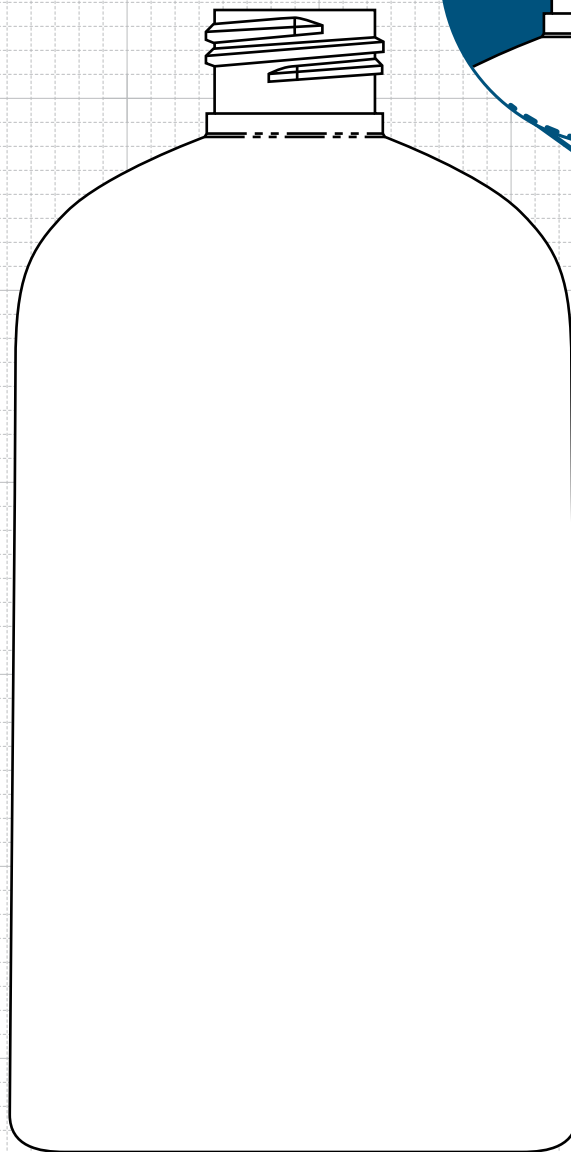

B  
A

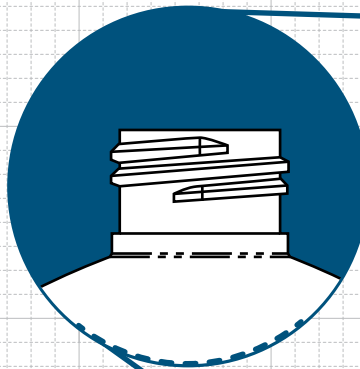

**NECK & THREAD DETAIL**

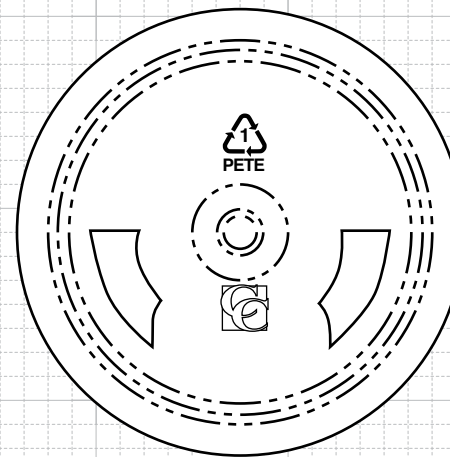
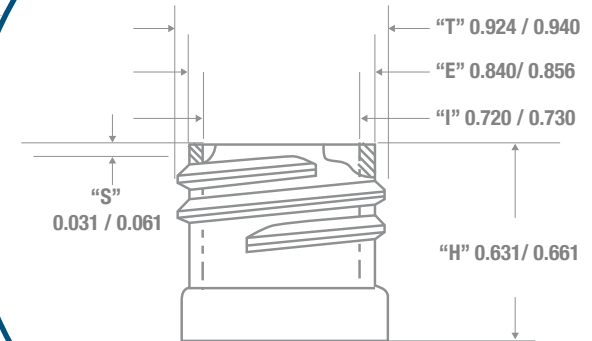

**BOTTOM VIEW**

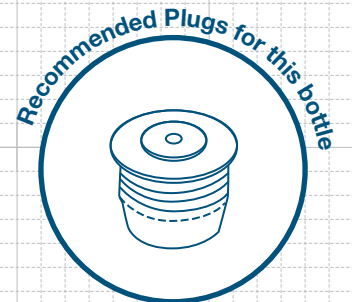

**FRICION FIT**

PRINTING SPECIFICATIONS: 500 ml BOSTON ROUND 24/410

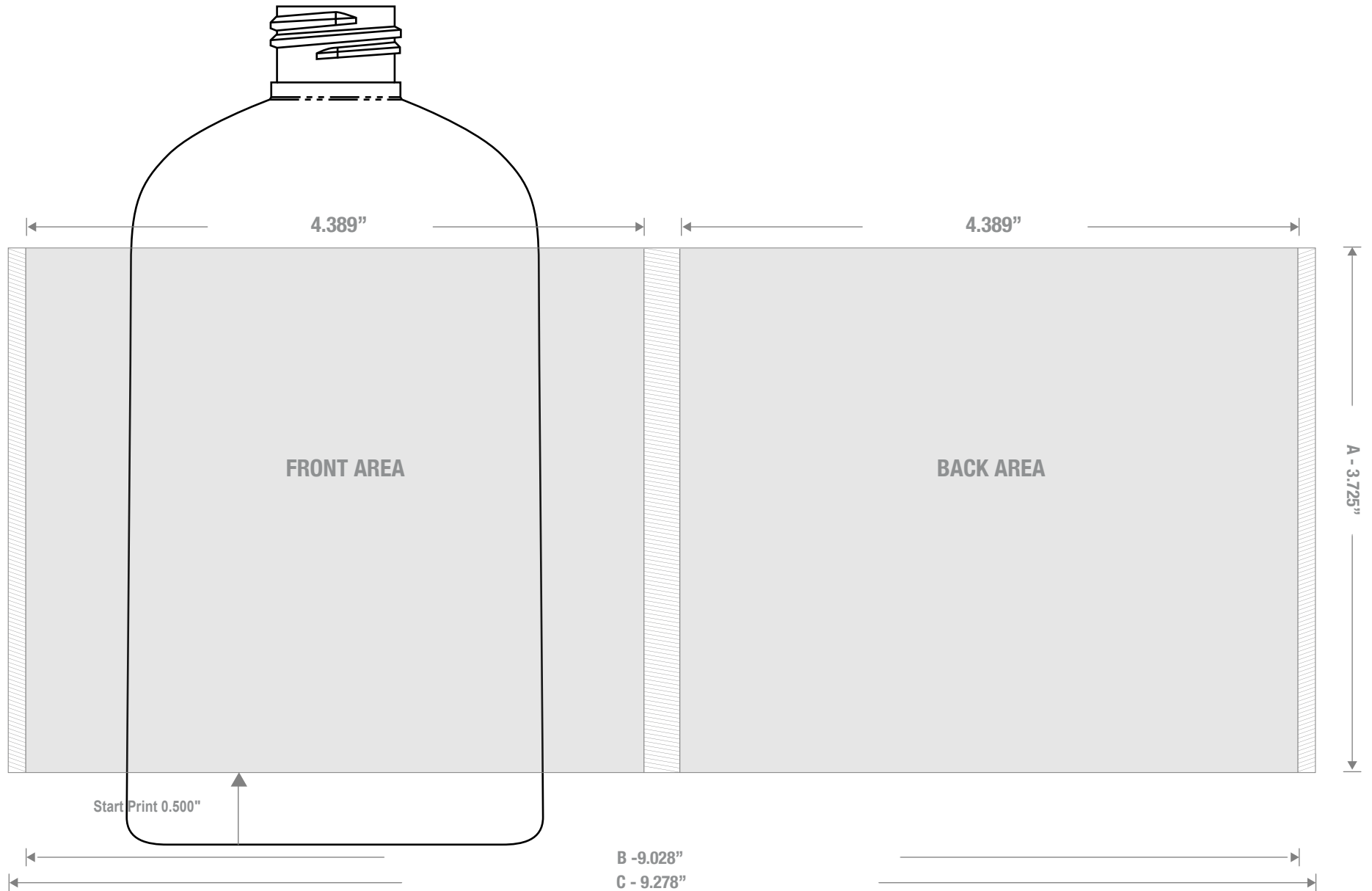

1700 S Hellman Ave, Ontario, California 91761  
 Phone: (909) 930-3610 | Fax: (909) 930-3640  
 e-mail: [info@classiccontainers.com](mailto:info@classiccontainers.com)  
[www.classiccontainers.com](http://www.classiccontainers.com)

**A - Total Height.**  
**B - Max. Decorating Area.**  
**C - Total bottle circumference.**  
 - Unprintable area.