



Drawing:  
**300 ml Boston Round 24/415**

Stock Code:  
**030000060251700**

Manufacturing Process:  
**Stretch Blow Molding**

Overflow Capacity:  
**316 - 333 ml (10.7 - 11.3 oz)**

Gram Weight:  
**25 ± 1**

Neck Finish:  
**24/415**

Base Width (A):  
**2.465 ± 0.050**

Overall Height (B):  
**5.470 ± 0.050**

Max Print Area (Height):  
**3.250"**

Max Print Area (Width):  
**7.574"**

Case Pack: **308**

Case Weight (lb): **19.9 ± 0.7**

Cases Per Pallet: **16**

Box Dimensions:  
**24 7/16 x 18 1/2 x 23**

Stock Material:



**CLASSIC CONTAINERS INC**  
1700 S. Hellman Ave.  
Ontario, CA 91761  
Phone: 909-930-3610  
e-mail: info@classiccontainers.com  
[www.classiccontainers.com](http://www.classiccontainers.com)

### FRONT VIEW

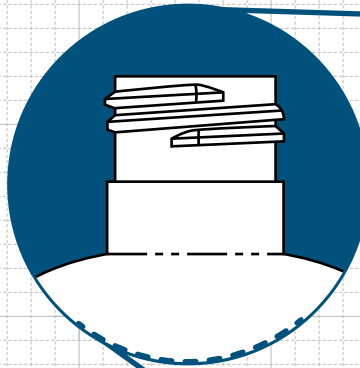
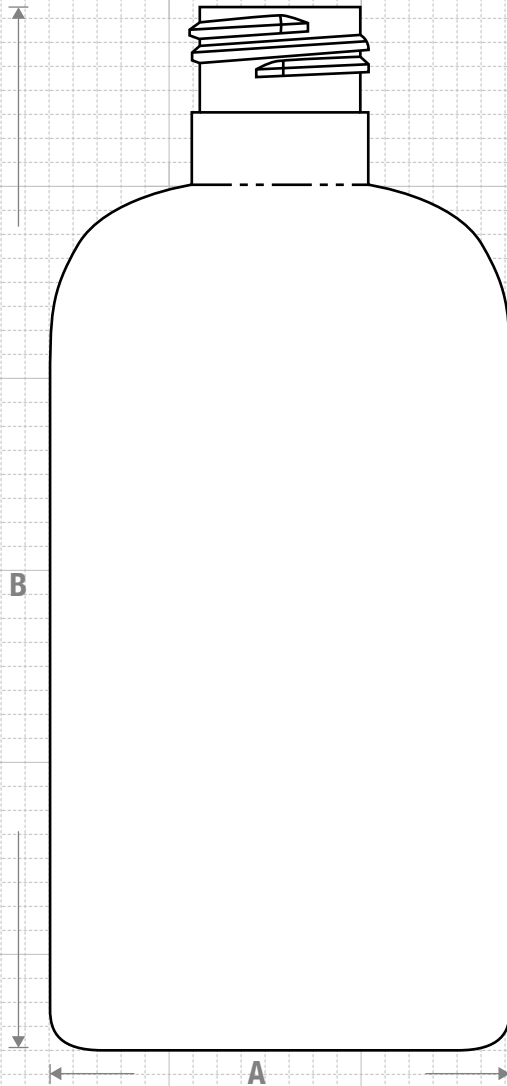

### NECK & THREAD DETAIL

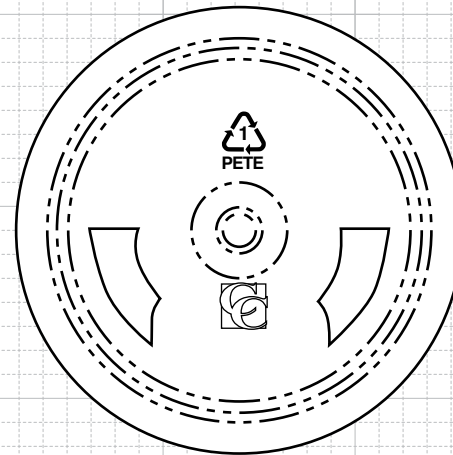
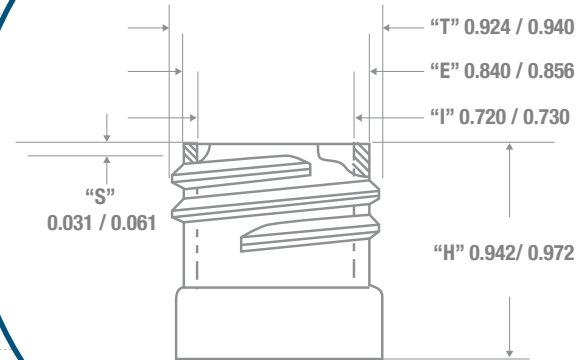

### BOTTOM VIEW

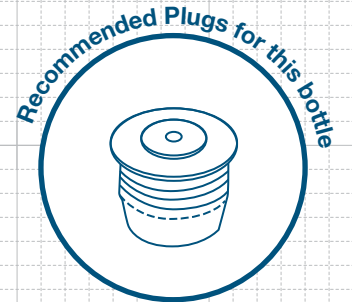

### FRICITION FIT



# LABELING SPECIFICATIONS: 300 ml BOSTON ROUND 24/415



1700 S Hellman Ave, Ontario, California 91761  
Phone: (909) 930-3610 | Fax: (909) 930-3640  
e-mail: [info@classiccontainers.com](mailto:info@classiccontainers.com)  
[www.classiccontainers.com](http://www.classiccontainers.com)

**A - Total Height.**  
**B - Max. Decorating Area.**