

NECK & THREAD DETAIL

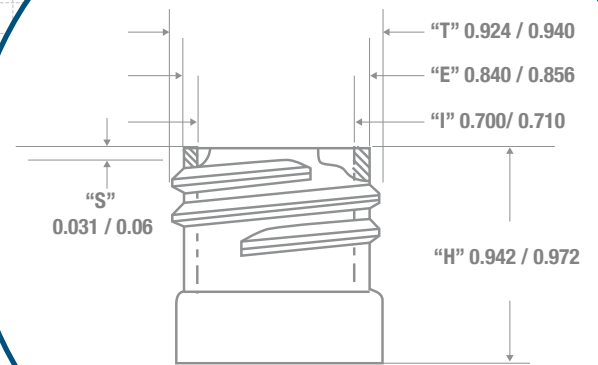

FRONT VIEW

SIDE VIEW

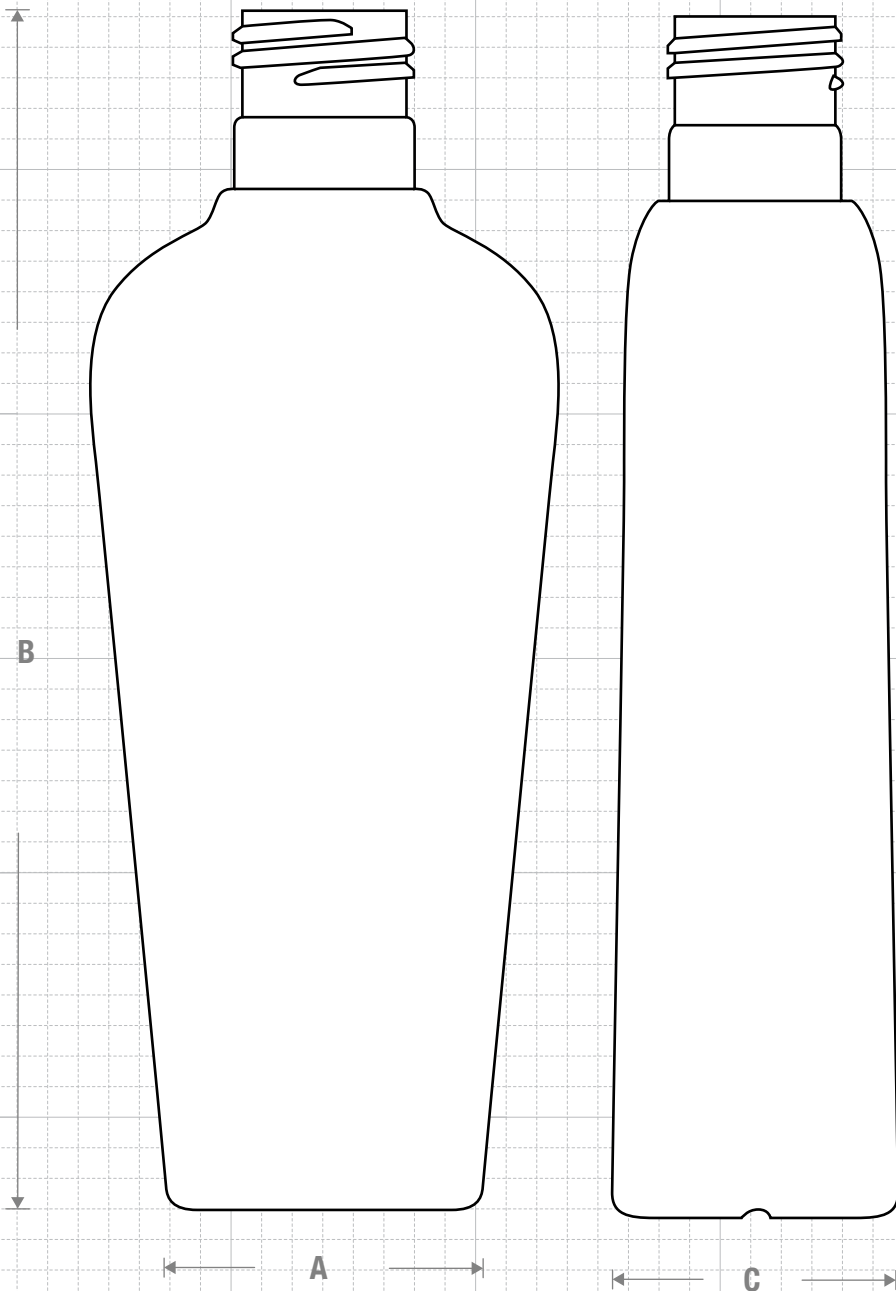

Recommended Plugs for this bottle

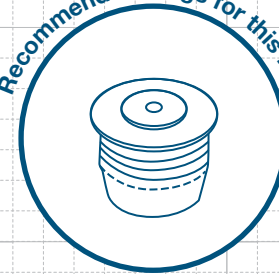

FRICITION FIT

- HDPE
- LDPE
- PP
- OTHER

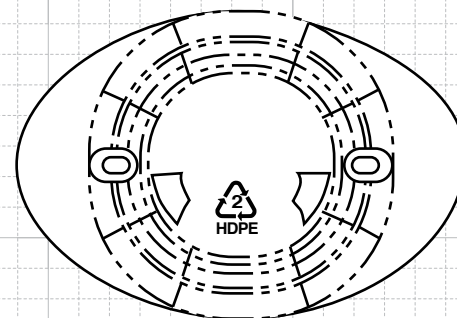

BOTTOM VIEW



CLASSIC CONTAINERS INC
 1700 S. Hellman Ave.
 Ontario, CA 91761
 Phone: 909-930-3610
 e-mail: info@classiccontainers.com
 www.classiccontainers.com

Drawing: 6 oz Vail Oval 24/415	Gram Weight: 20 ± 2	Max Print Area (Height): 4.000	Cases Per Pallet: 16
Stock Code: 000600100250000	Neck Finish: 24/415	Max Print Area (Width): Shoulder: 1.453" Base: 0.875"	Box Dimensions: 24 7/16 x 18 1/2 x 23
Manufacturing Process: Extrusion Blow Molding	Base Width (A) Base Deep (C): 1.650± 0.050 1.535± 0.050	Case Pack: 516	Stock Material:
Overflow Capacity: 189 - 200 ml (6.4 - 6.8 oz)	Overall Height (B): 6.320 ± 0.050	Case Weight (lb): 25.7 ± 2.3	Rev #2 07/2016 Drawing not exactly to size.

