



Drawing:
4 oz Evolution 20/410

Stock Code:
000400330201700

Manufacturing Process:
Stretch Blow Molding

Overflow Capacity:
124 - 136 ml (4.2 - 4.6 oz)

Gram Weight:
15 ± 1

Neck Finish:
20/410

Base Width (A):
1.550 ± 0.050

Overall Height (B):
5.285 ± 0.050

Max Print Area (Height):
3.300"

Max Print Area (Width):
4.750"

Case Pack: 486

Case Weight (lb): 18.2 ± 1.1

Cases Per Pallet: 25

Box Dimensions:
23 5/8 x15 9/16 x17

Stock Material:



CLASSIC CONTAINERS INC
1700 S. Hellman Ave.
Ontario, CA 91761
Phone: 909-930-3610
e-mail: info@classiccontainers.com
www.classiccontainers.com

FRONT VIEW

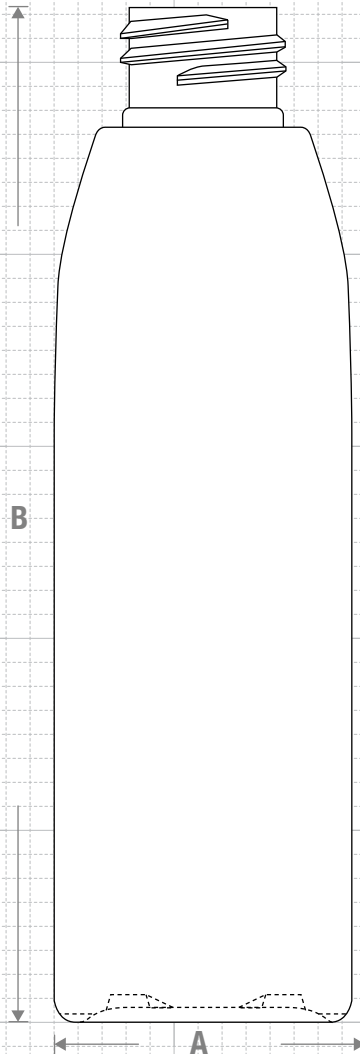

NECK & THREAD DETAIL

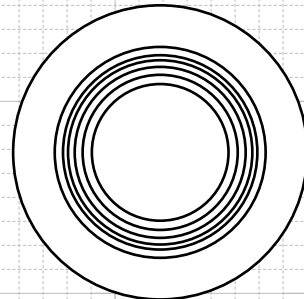
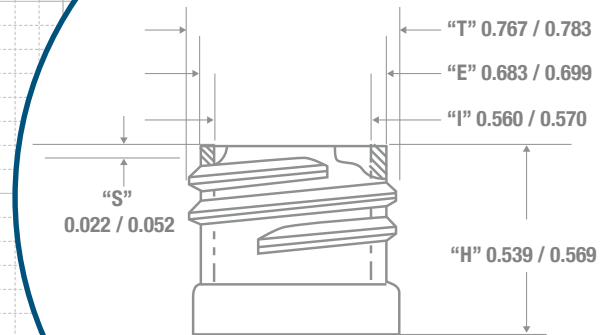

TOP VIEW

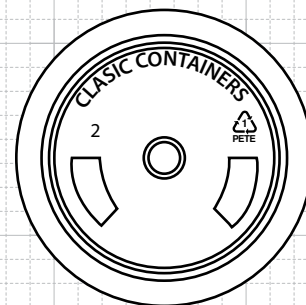

BOTTOM VIEW

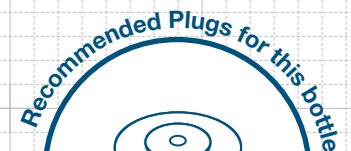
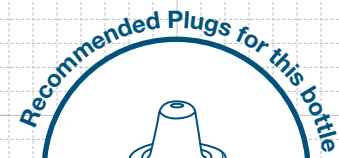

FRICITION FIT

PRINTING SPECIFICATIONS: 4 oz Evolution 20/410

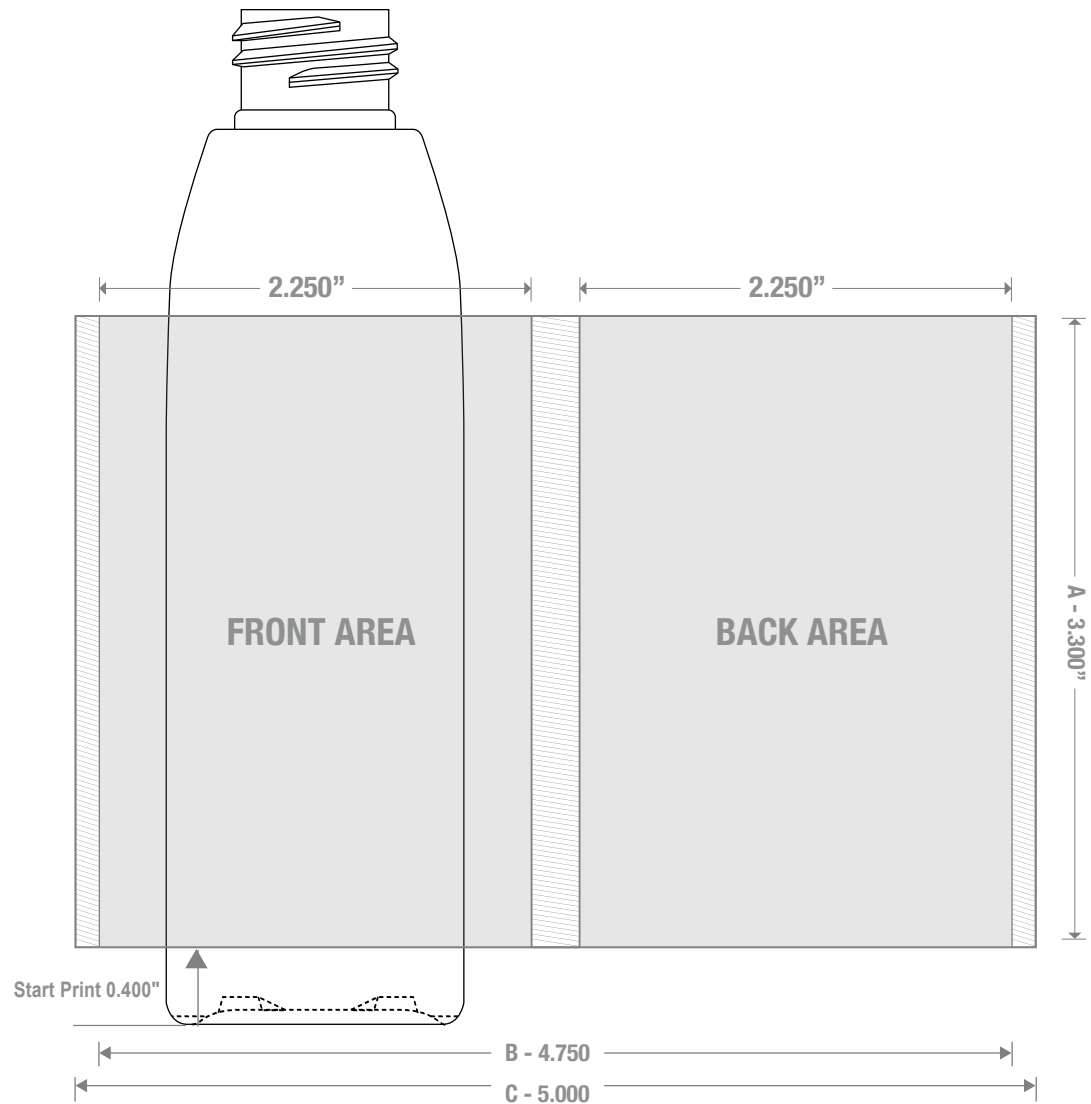

1700 S Hellman Ave, Ontario, California 91761
Phone: (909) 930-3610 | Fax: (909) 930-3640
e-mail: info@classiccontainers.com
www.classiccontainers.com

A - Total Height.
B - Max. Decorating Area.
C - Total bottle circumference.
☒ - Unprintable area.