

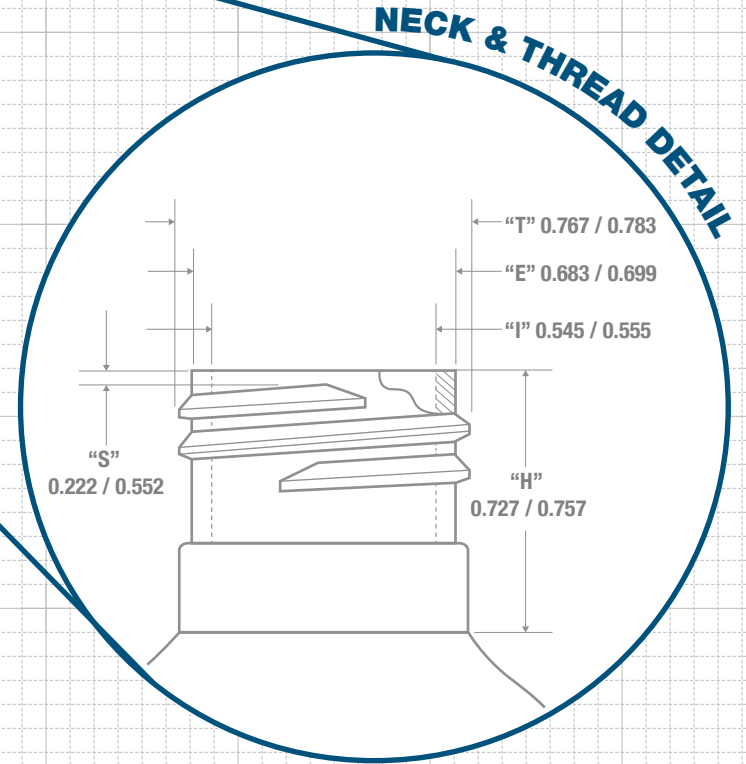

FRONT VIEW

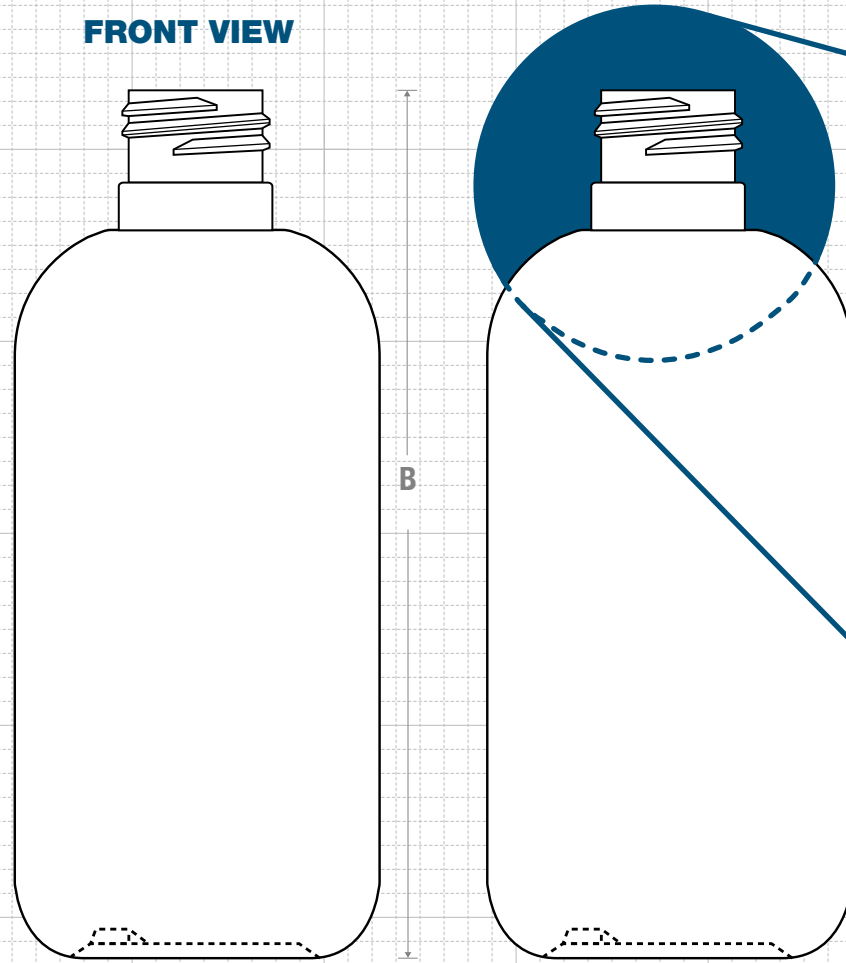

Drawing:
5 oz Boston Round 20/415

Stock Code:
000500060210000

Manufacturing Process:
Extrusion Blow Molding

Overflow Capacity:
153 - 165 ml (5.2 - 5.6 oz)

Gram Weight:
13.5 ± 1

Neck Finish:
20/415

Base Width (A):
1.900 ± 0.050

Overall Height (B):
4.520 ± 0.050

Max Print Area (Height):
2.750"

Max Print Area (Width):
5.750"

Case Pack: 403

Case Weight (lb): 14.1 ± 0.9

Cases Per Pallet: 25

Box Dimensions:
23 5/8 x 15 9/16 x 17

Stock Material:

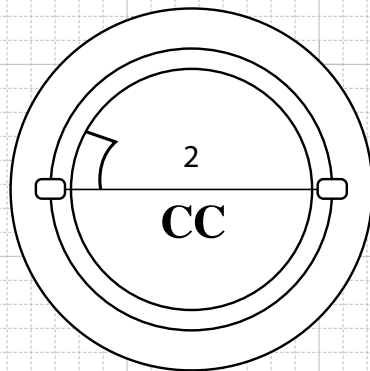

BOTTOM VIEW

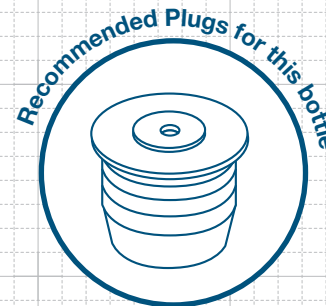

FRICION FIT

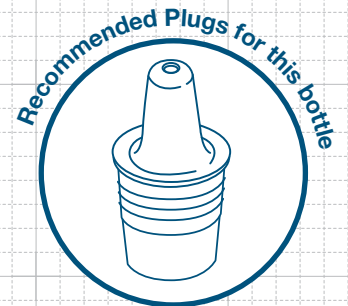

FRICION FIT

CLASSIC CONTAINERS INC
1700 S. Hellman Ave.
Ontario, CA 91761
Phone: 909-930-3610
e-mail: info@classiccontainers.com
www.classiccontainers.com

PRINTING SPECIFICATIONS: 5 oz BOSTON ROUND

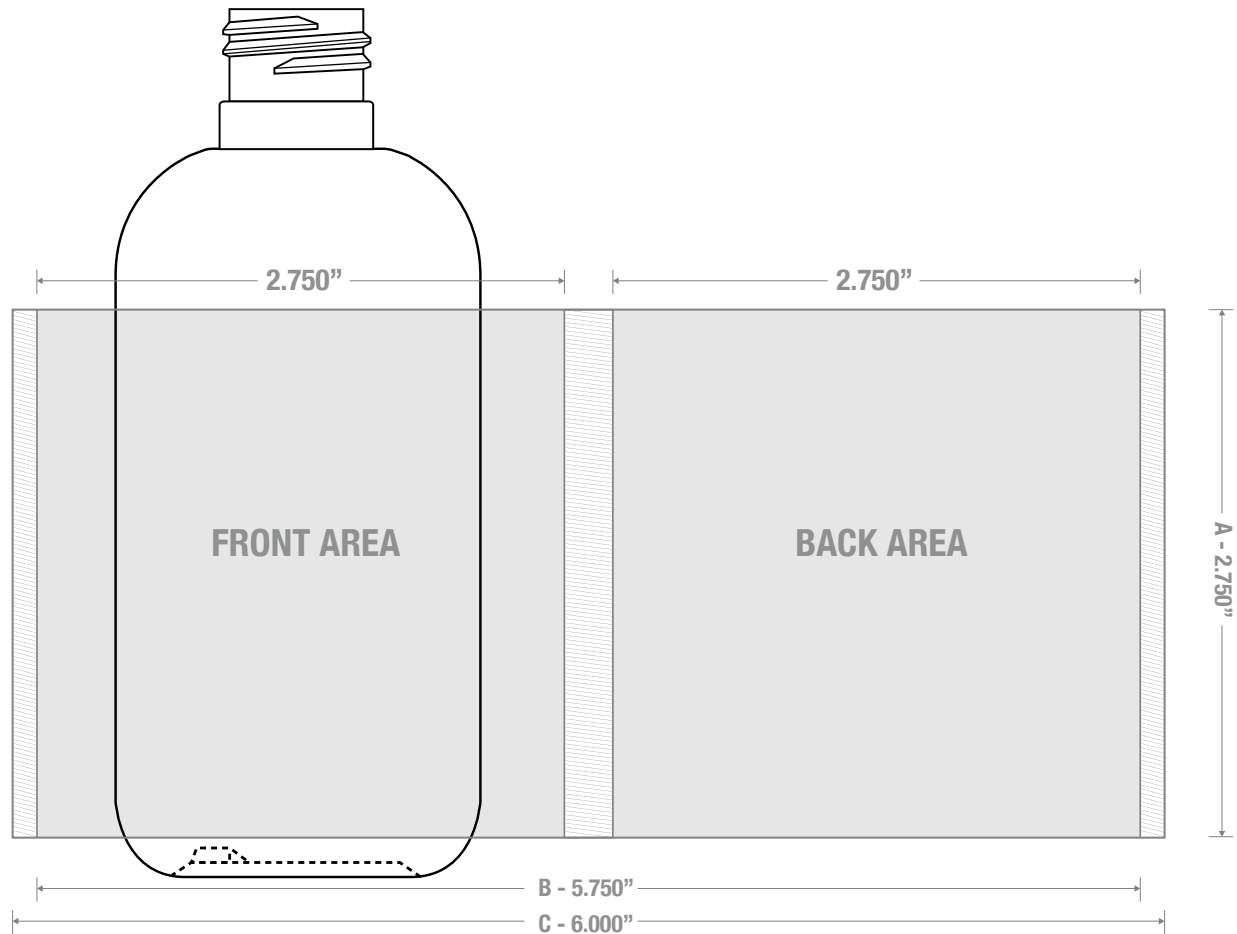

1700 S Hellman Ave, Ontario, California 91761
Phone: (909) 930-3610 | Fax: (909) 930-3640
e-mail: info@classiccontainers.com
www.classiccontainers.com

A - Total Height.
B - Max. Decorating Area.
C - Total bottle circumference.
▨ - Unprintable area.