

FRONT VIEW

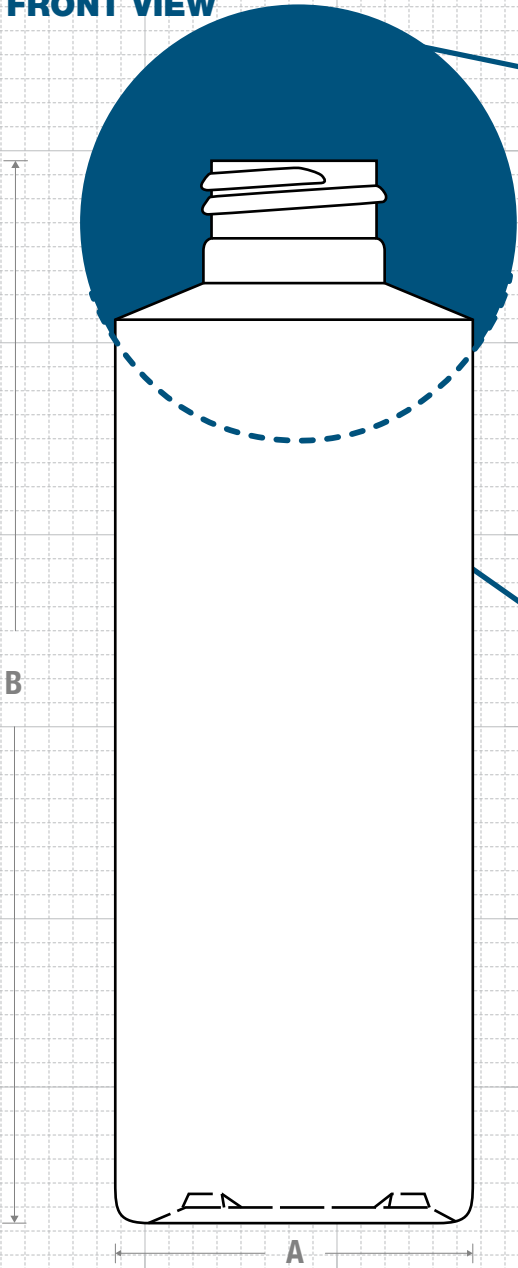

NECK & THREAD DETAIL

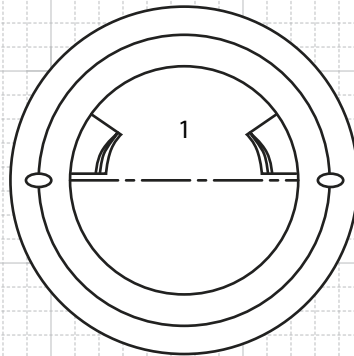
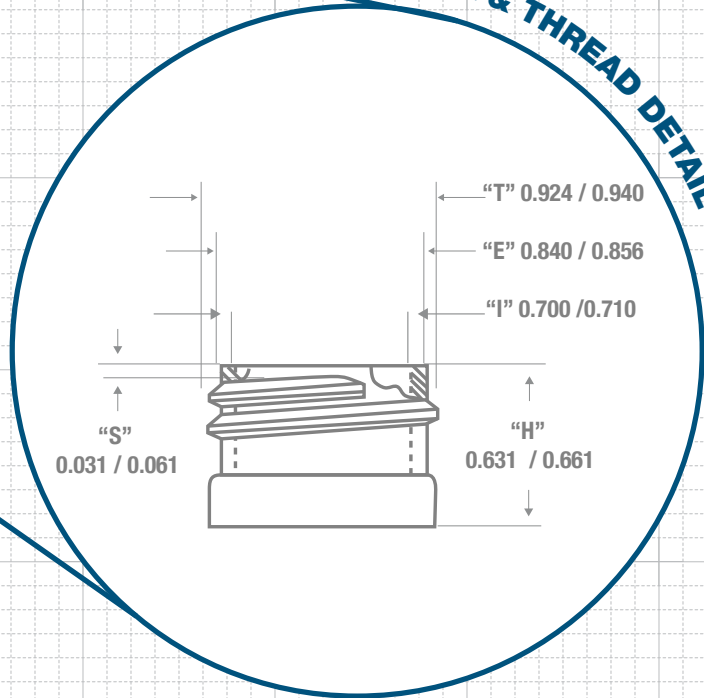

BOTTOM VIEW

Recommended Plugs for this bottle



FRICION FIT



CLASSIC CONTAINERS INC
 1700 S. Hellman Ave.
 Ontario, CA 91761
 Phone: 909-930-3610
 e-mail: info@classiccontainers.com
 www.classiccontainers.com

Drawing:
6 oz Cylinder Round 24/410

Gram Weight:
16 ± 2 grs

Max Print Area (Height):
4.187"

Cases Per Pallet: **16**

Stock Code:
000600010240000

Neck Finish:
24/410

Max Print Area (Width):
5.562"

Box Dimensions:
24 7/16 x 18 1/2 x 23

Manufacturing Process:
Extrusion Blow Molding

Base Width (A):
1.860 ± 0.050

Case Pack: **572**

Stock Material:



Overflow Capacity:
195 - 207 ml (6.6- 7.0 oz)

Overall Height (B):
5.490 ± 0.050

Case Weight (lb): **23 ± 2.5**

Rev #4 -11/2016

Drawing not exactly to size.

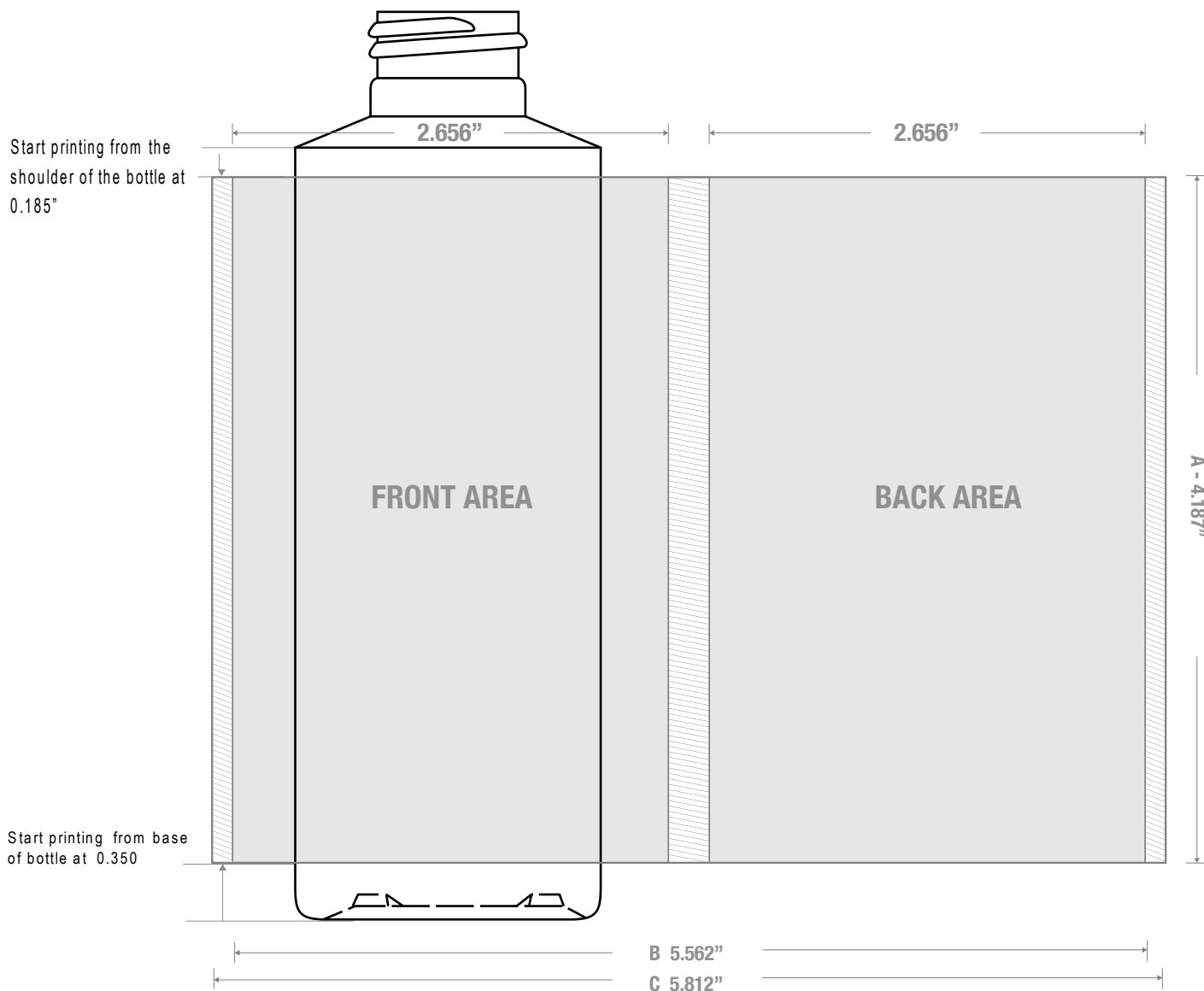

1700 S Hellman Ave, Ontario, California 91761
 Phone: (909) 930-3610 | Fax: (909) 930-3640
 e-mail: info@classiccontainers.com
www.classiccontainers.com

A - Total Height.
B - Max. Decorating Area.
C - Total bottle circumference.
 [Hatched Box] - Unprintable area.

LABELING SPECIFICATIONS: 6 oz CYLINDER ROUND 24 /410



1700 S Hellman Ave, Ontario, California 91761
Phone: (909) 930-3610 | Fax: (909) 930-3640
e-mail: info@classiccontainers.com
www.classiccontainers.com

A - Total Height.
B - Max. Decorating Area.