

NECK & THREAD DETAIL

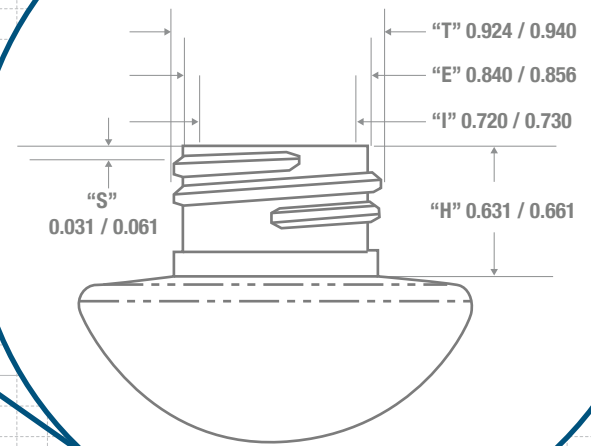

FRONT VIEW

RIGHT VIEW

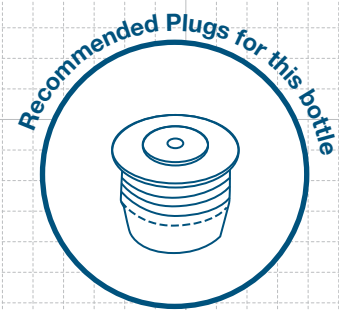
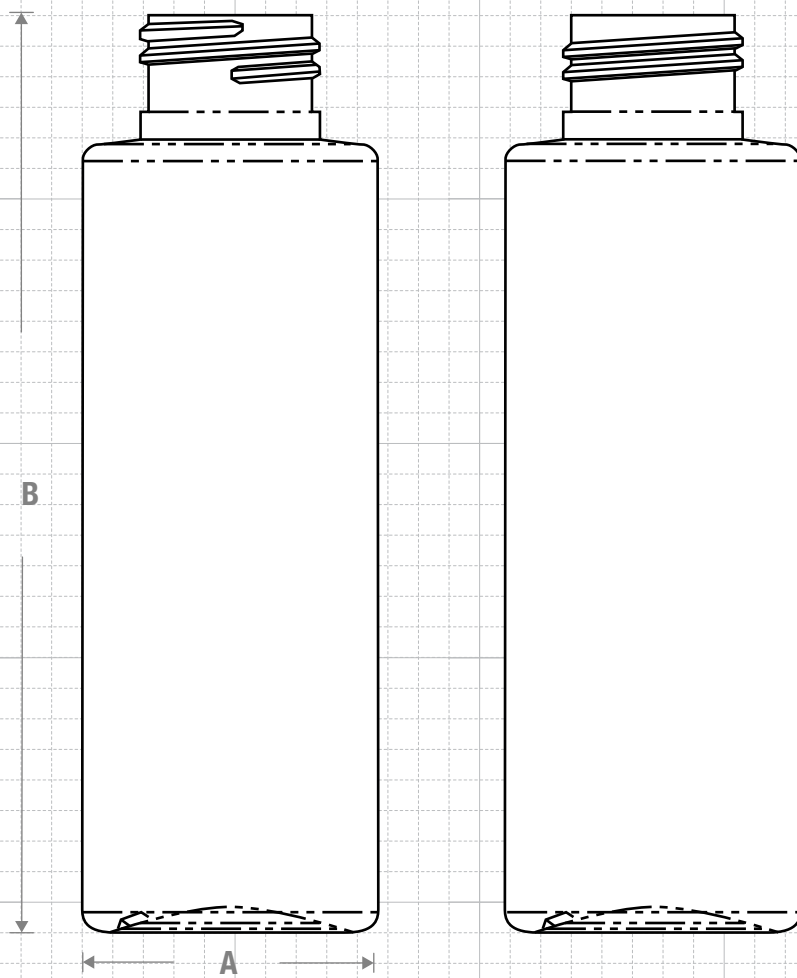

FRICITION FIT

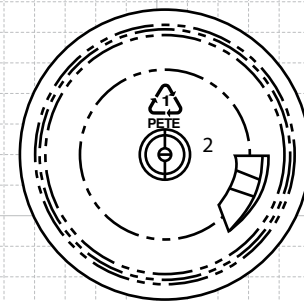

BOTTOM VIEW



CLASSIC CONTAINERS INC
 1700 S. Hellman Ave.
 Ontario, CA 91761
 Phone: 909-930-3610
 e-mail: info@classiccontainers.com
 www.classiccontainers.com

Drawing:
100 ml Cylinder Round 24/410

Gram Weight:
20 ± 1

Max Print Area (Height):
3.407"

Cases Per Pallet: **25**

Stock Code:
010000010241700

Neck Finish:
24/410

Max Print Area (Width):
4.638"

Box Dimensions:
23 5/8 x15 9/16 x17

Manufacturing Process:
Stretch Blow Molding

Base Width (A):
1.540 ± 0.050

Case Pack: **525**

Stock Material:



Overflow Capacity:
112 - 121 ml (3.80 - 4.10 oz)

Overall Height (B):
4.773 ± 0.050

Case Weight (lb): **24.1 ± 1.2**

Rev #2 04/2018

Drawing not exactly to size.

