

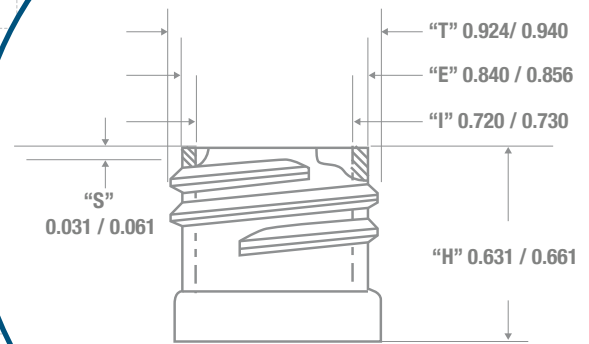

### NECK & THREAD DETAIL

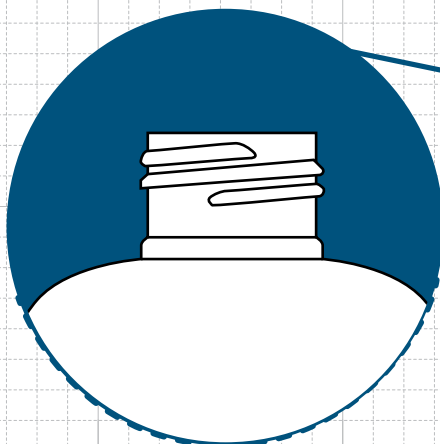

### FRONT VIEW

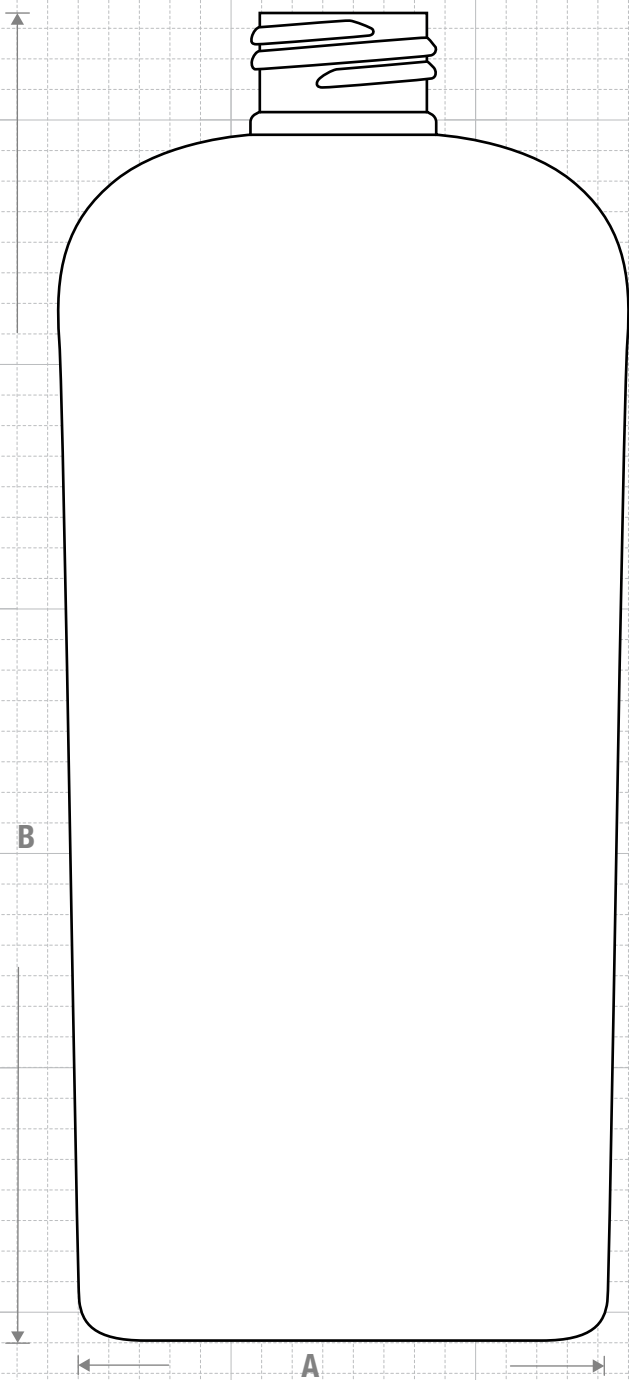

### SIDE VIEW

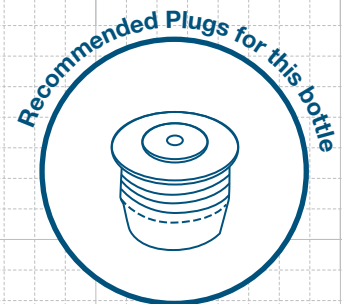
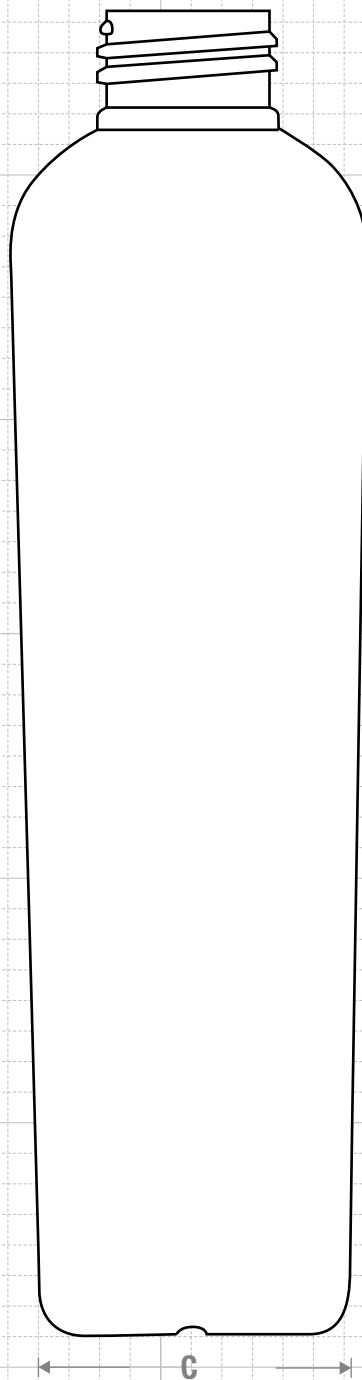

### FRICION FIT

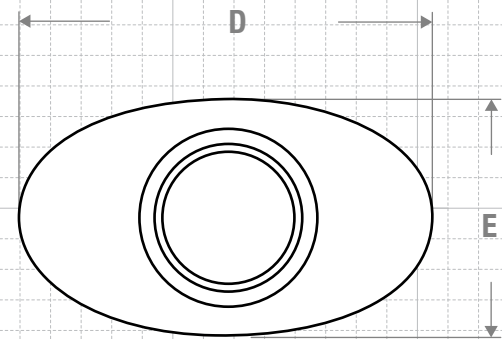

### TOP VIEW

D Shoulder Width: 2.943±0.050  
E Shoulder Depth: 1.802±0.050

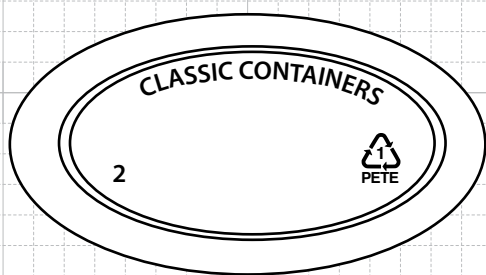

### BOTTOM VIEW



**CLASSIC CONTAINERS INC**  
1700 S. Hellman Ave.  
Ontario, CA 91761  
Phone: 909-930-3610  
e-mail: info@classiccontainers.com  
www.classiccontainers.com

Drawing:  
**12 oz Classic Oval 24/410**

Gram Weight:  
**31 ± 1**

Max Print Area (Height):  
**5.000"**

Cases Per Pallet: **16**

Stock Code:  
**001200230241700**

Neck Finish:  
**24/410**

Max Print Area (Width):  
**1.937"**

Box Dimensions:  
**24 7/16 x 18 1/2 x 23**

Manufacturing Process:  
**Stretch Blow Molding**

Base Width (A) Base Deep (C):  
**2.730± 0.050 1.593± 0.050**

Case Pack: **289**

Stock Material:



Overflow Capacity:  
**360 - 378 ml (12.2 - 12.8oz)**

Overall Height (B):  
**6.913 ± 0.050**

Case Weight (lb): **22.7± 0.6**

Rev #2 03/2016

Drawing not exactly to size.

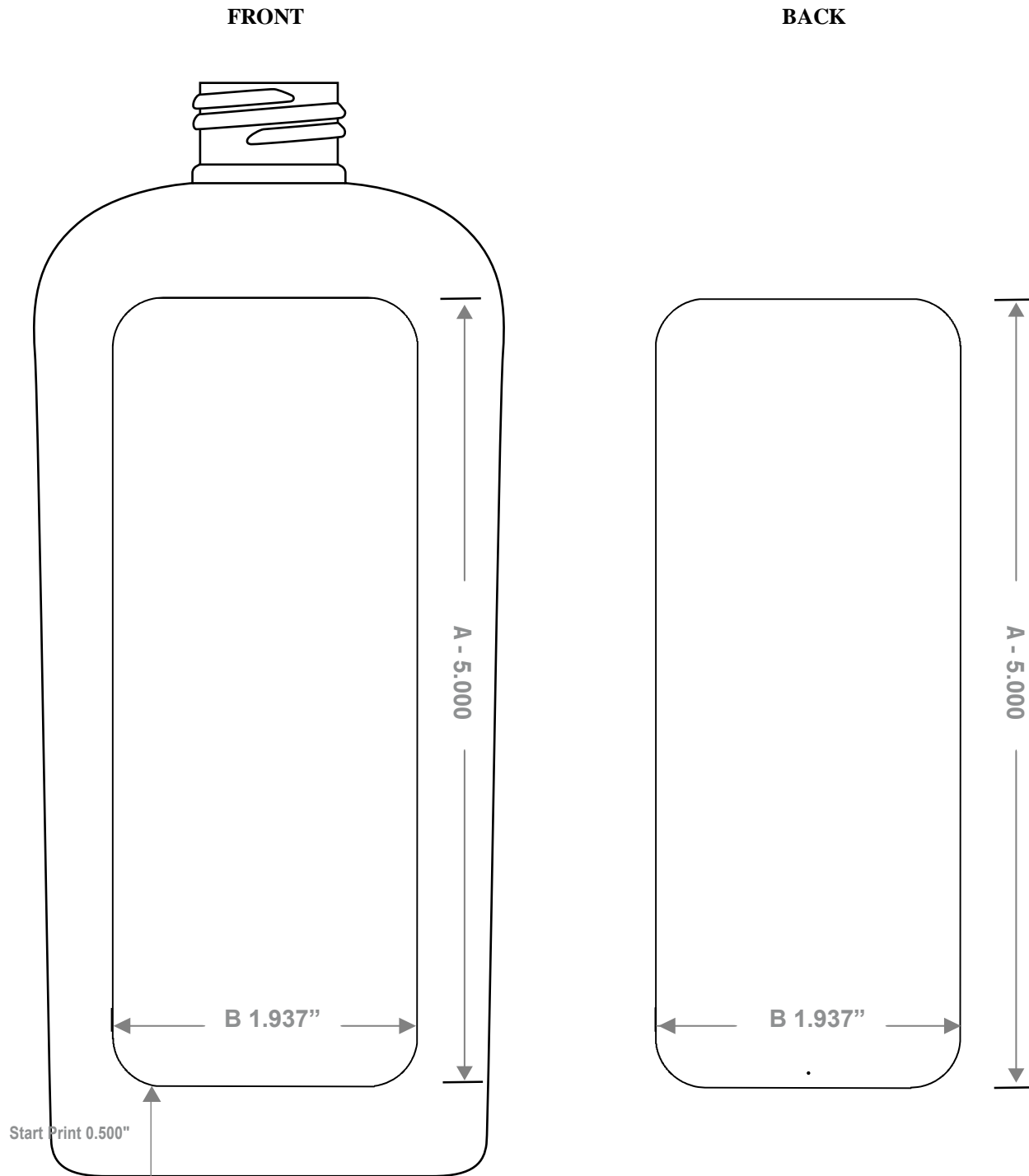

**A - Total height.**  
**B - max. decorating area.**

March 4, 2014

**12 OZ CLASSIC OVAL PETE  
LABELING AREA**

