

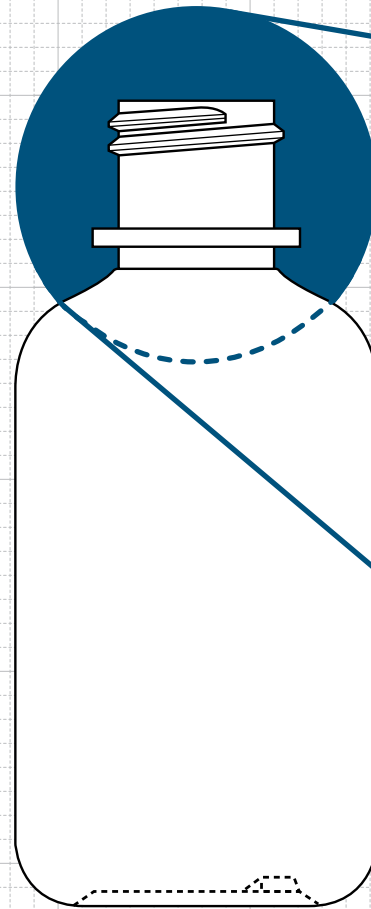

FRONT VIEW

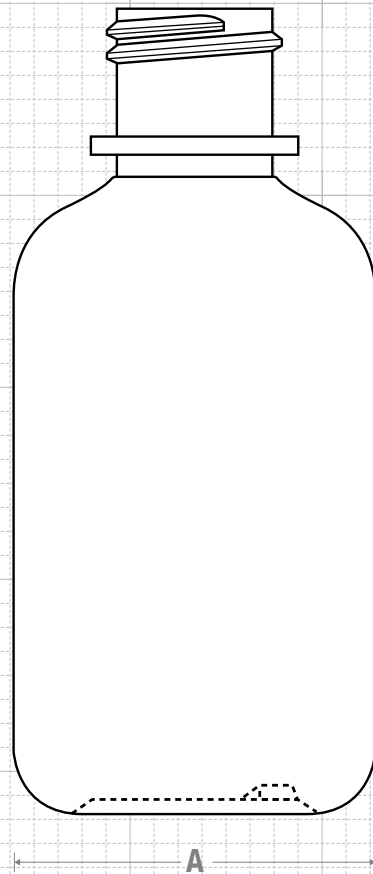

NECK & THREAD DETAIL

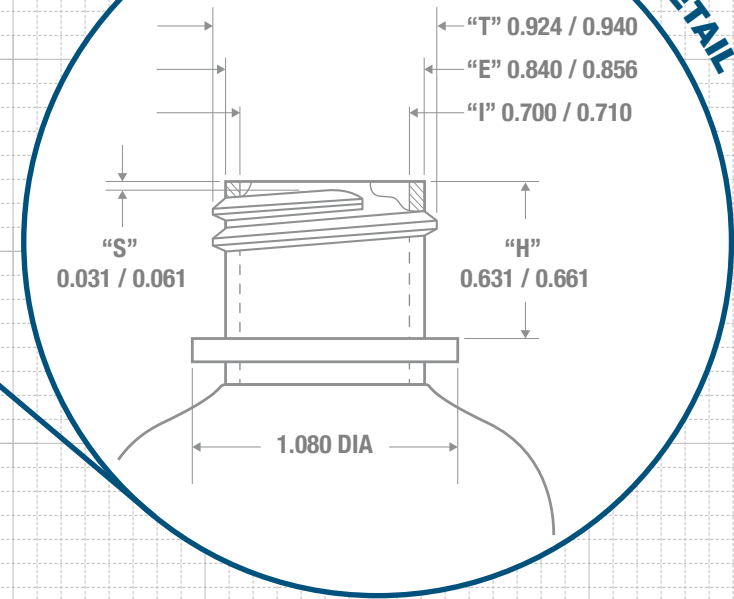

Drawing:
4 oz Boston Round 24/410 W/Ring

Stock Code:
00040006024R0000

Manufacturing Process:
Extrusion Blow Molding

Overflow Capacity:
130 - 142 ml (4.4 - 4.8 oz)

Gram Weight:
13.5 ± 1

Neck Finish:
24/410 W/R

Base Width (A):
1.885 ± 0.050

Overall Height (B):
4.195 ± 0.050

Max Print Area (Height):
2.187"

Max Print Area (Width):
5.687"

Case Pack: **480**

Case Weight (lb): **16.4 ± 1.0**

Cases Per Pallet: **25**

Box Dimensions:
23 5/8 x 15 9/16 x 17

Stock Material:



CLASSIC CONTAINERS INC
1700 S. Hellman Ave.
Ontario, CA 91761
Phone: 909-930-3610
e-mail: info@classiccontainers.com
www.classiccontainers.com

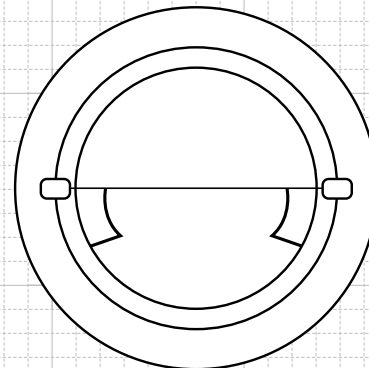

BOTTOM VIEW

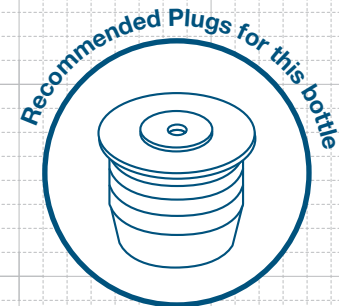

PRINTING SPECIFICATIONS: 4 oz BOSTON ROUND

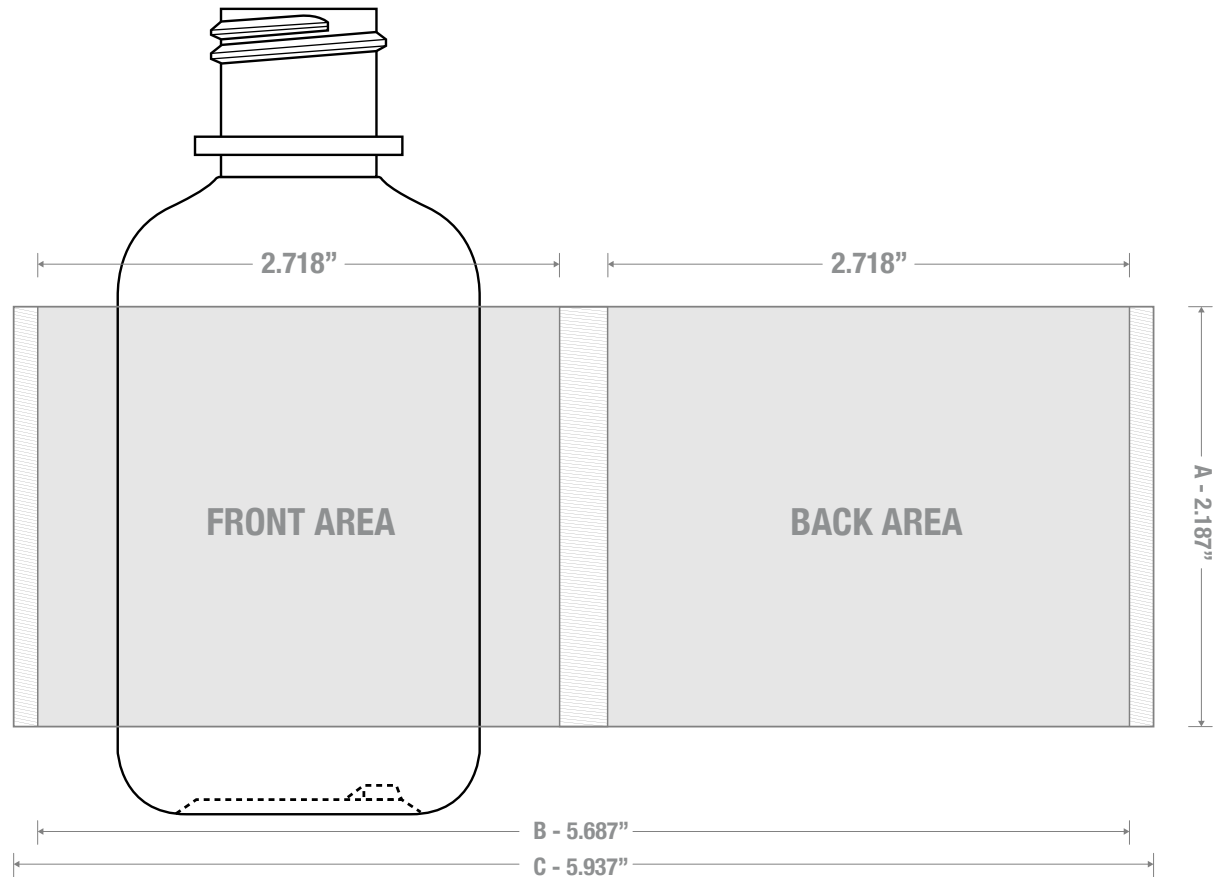

1700 S Hellman Ave, Ontario, California 91761
Phone: (909) 930-3610 | Fax: (909) 930-3640
e-mail: info@classiccontainers.com
www.classiccontainers.com

A - Total Height.
B - Max. Decorating Area.
C - Total bottle circumference.
▨ - Unprintable area.

LABELING SPECIFICATIONS: 4 oz BOSTON ROUND

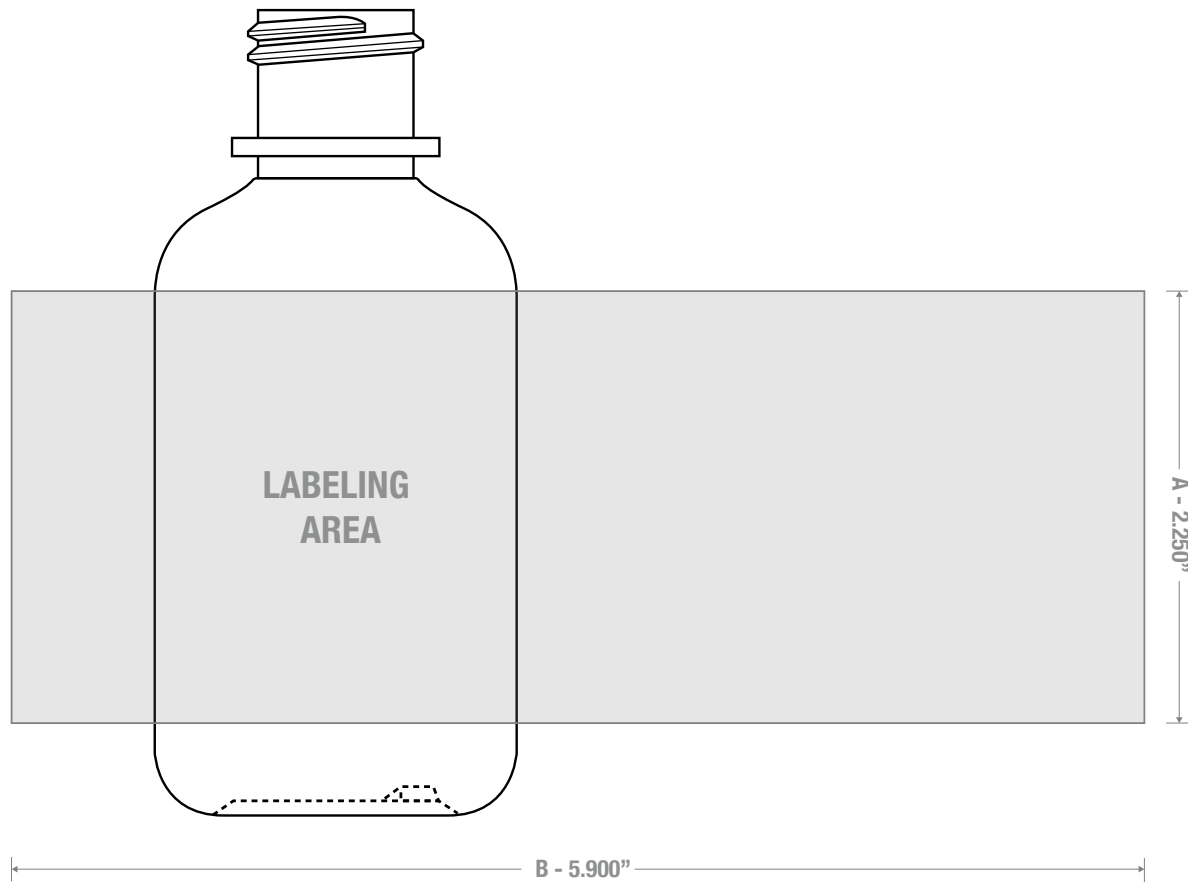

1700 S Hellman Ave, Ontario, California 91761
Phone: (909) 930-3610 | Fax: (909) 930-3640
e-mail: info@classiccontainers.com
www.classiccontainers.com

A - Total Height.
B - Max. Decorating Area.