

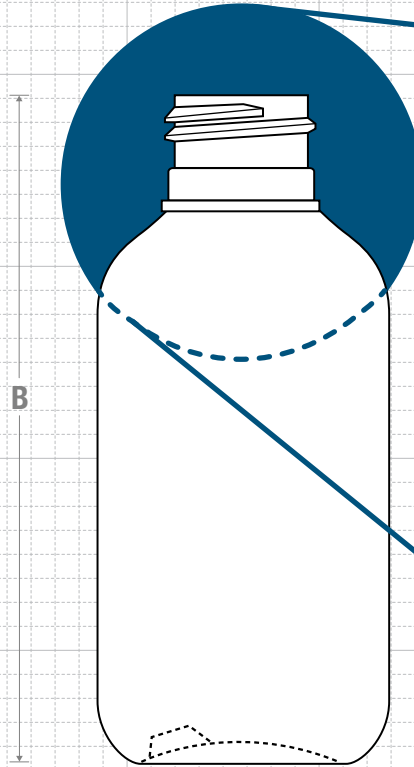

FRONT VIEW

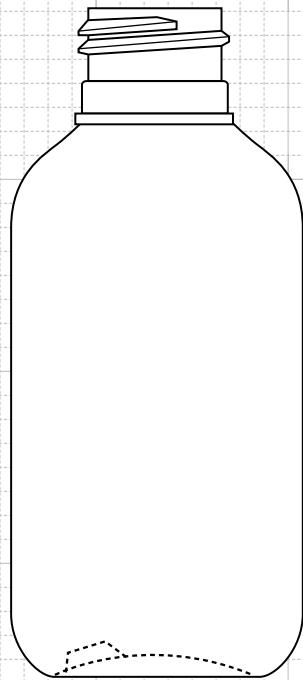

NECK & THREAD DETAIL

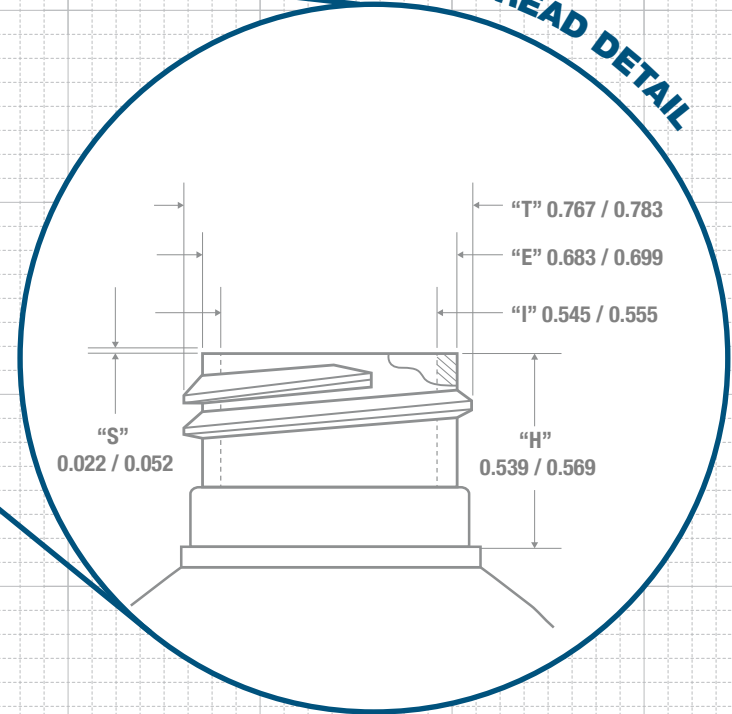

A

B

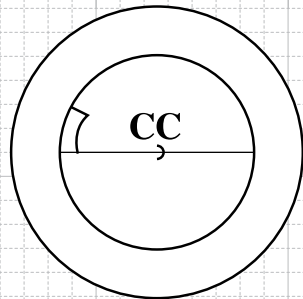

BOTTOM VIEW

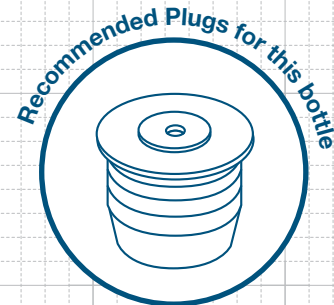

FRICITION FIT

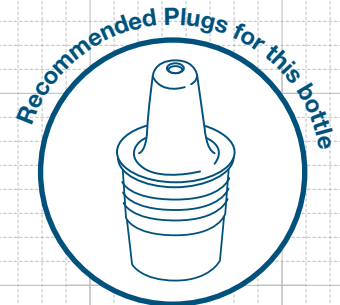

FRICITION FIT

Drawing:
2 oz (60 ml) Boston Round
20/410

Stock Code:
00020006020000

Manufacturing Process:
Extrusion Blow Molding

Overflow Capacity:
68 - 77 ml (2.30 - 2.60 oz)

Gram Weight:
8.5 ± 1

Neck Finish:
20/410

Base Width (A):
1.519 ± 0.050

Overall Height (B):
3.472 ± 0.050

Max Print Area (Height):
1.875"

Max Print Area (Width):
4.563"

Case Pack: 810

Case Weight (lb): 17.2 ± 1.8

Cases Per Pallet: 25

Box Dimensions:
23 5/8 x 15 9/16 x 17

Stock Material:



CLASSIC CONTAINERS INC
1700 S. Hellman Ave.
Ontario, CA 91761
Phone: 909-930-3610
e-mail: info@classiccontainers.com
www.classiccontainers.com



Other Material Options

Stock Material: MD/PE,
HD/PE, MD/ST
Case Pack: 855
Case Weight (lb): 18.2 ± 1.9

PRINTING SPECIFICATIONS: 2 oz BOSTON ROUND

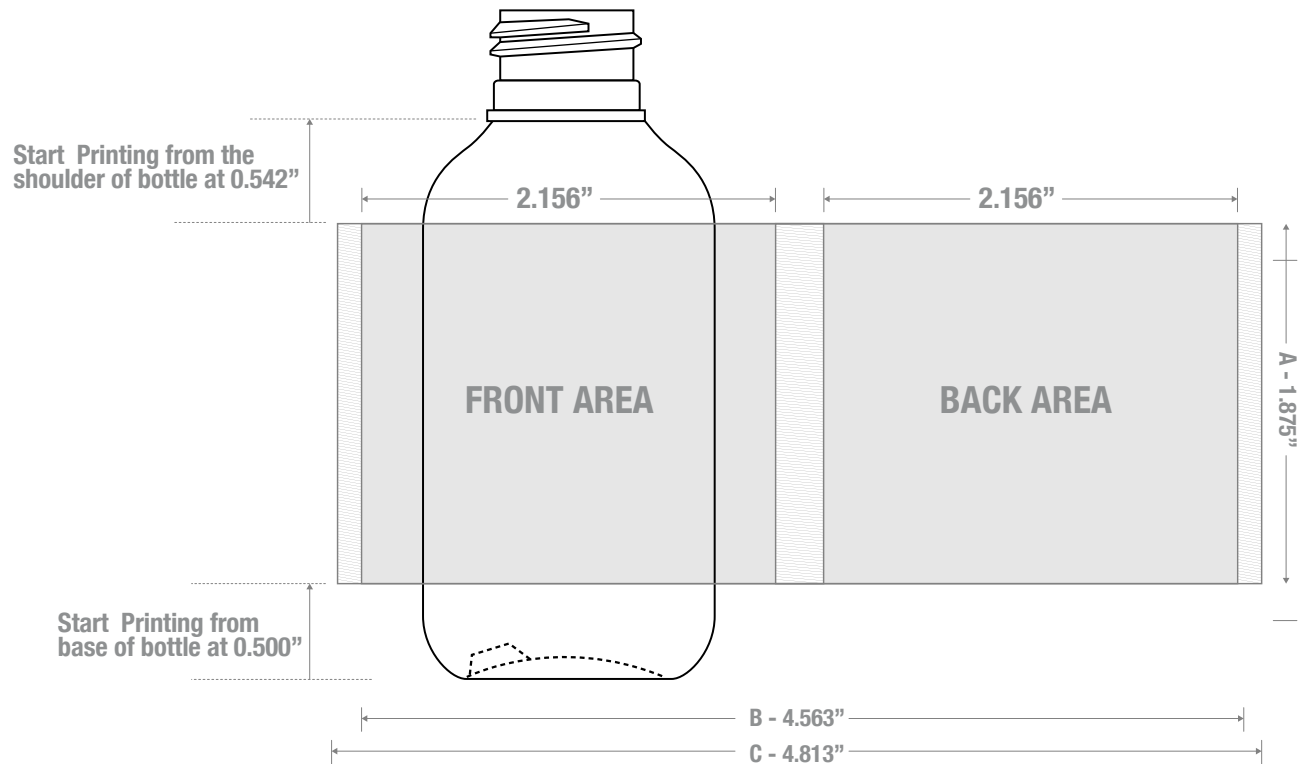

1700 S Hellman Ave, Ontario, California 91761
Phone: (909) 930-3610 | Fax: (909) 930-3640
e-mail: info@classiccontainers.com
www.classiccontainers.com

A - Total Height.
B - Max. Decorating Area.
C - Total bottle circumference.
[Hatched Box] - Unprintable area.

LABELING SPECIFICATIONS: 2 oz BOSTON ROUND

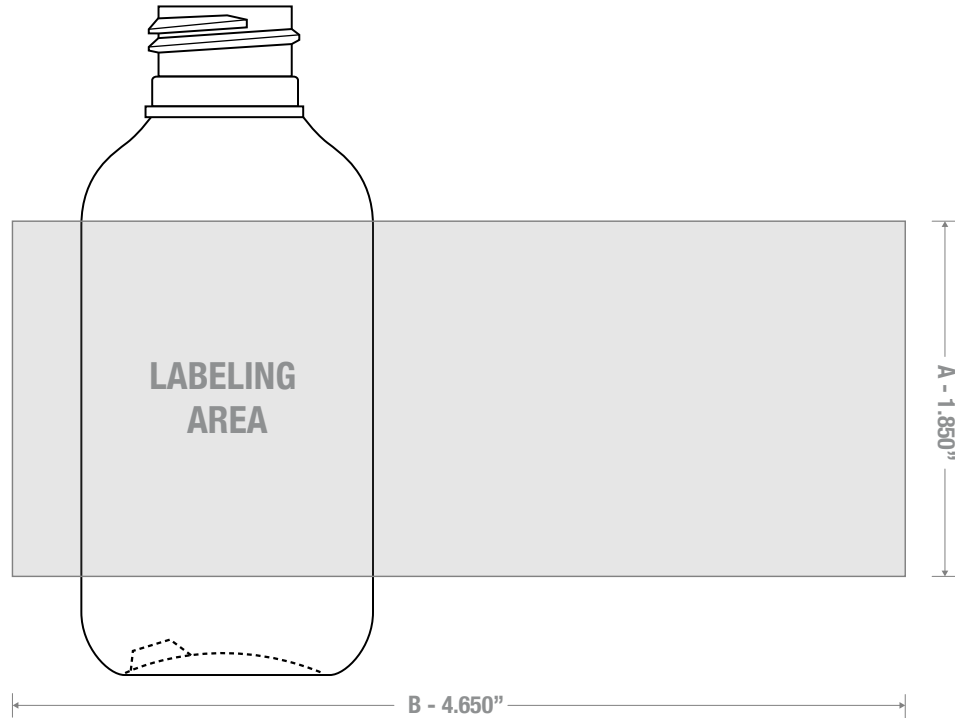

1700 S Hellman Ave, Ontario, California 91761
Phone: (909) 930-3610 | Fax: (909) 930-3640
e-mail: info@classiccontainers.com
www.classiccontainers.com

A - Total Height.
B - Max. Decorating Area.