



Drawing:  
5 oz Sleek Cylinder 24/410

Stock Code:  
000500490240000

Manufacturing Process:  
Extrusion Blow Molding

Overflow Capacity:  
162 - 174 ml (5.5 - 5.9 oz)

Gram Weight:  
18 ± 1

Neck Finish:  
24/410

Base Width (A):  
1.880 ± 0.050

Overall Height (B):  
4.650 ± 0.050

Max Print Area (Height):  
3.250"

Max Print Area (Width):  
5.625"

Case Pack: 351

Case Weight (lb): 16.1 ± 0.8

Cases Per Pallet: 25

Box Dimensions:  
23 5/8 x 15 9/16 x 17

Stock Material:



**CLASSIC CONTAINERS INC**  
1700 S. Hellman Ave.  
Ontario, CA 91761  
Phone: 909-930-3610  
e-mail: info@classiccontainers.com  
www.classiccontainers.com

### FRONT VIEW

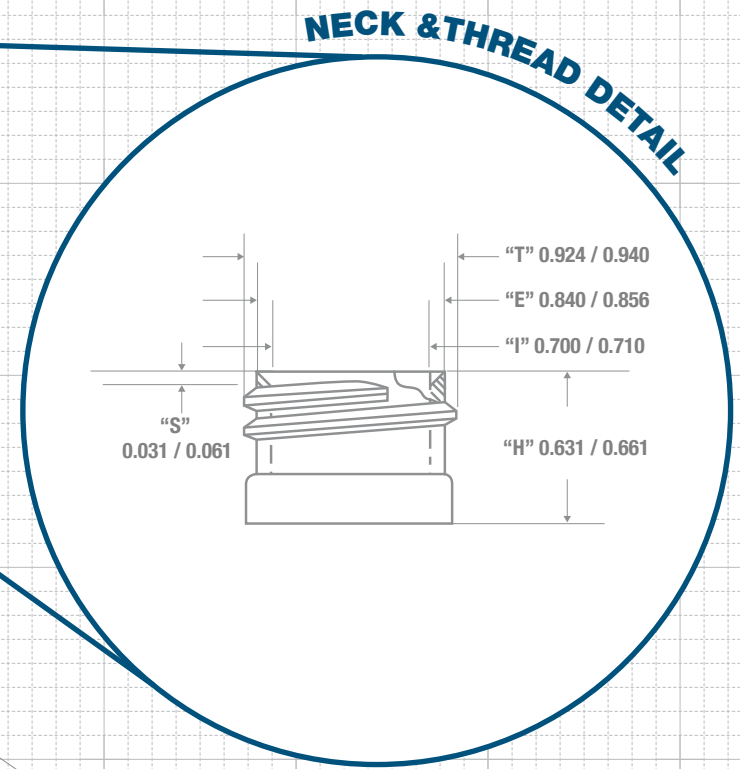
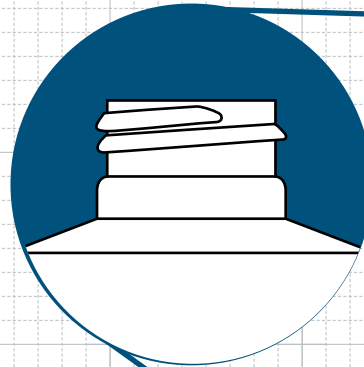
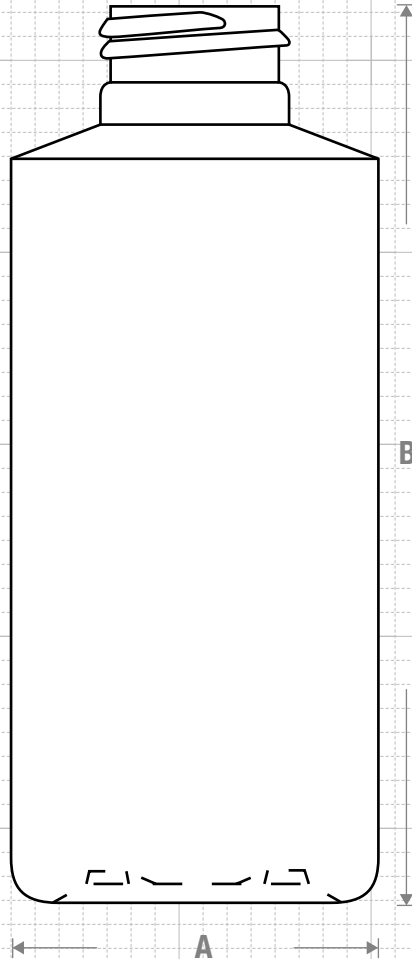

### NECK & THREAD DETAIL



Dome Cap On  
5 oz Sleek Cylinder

5.220

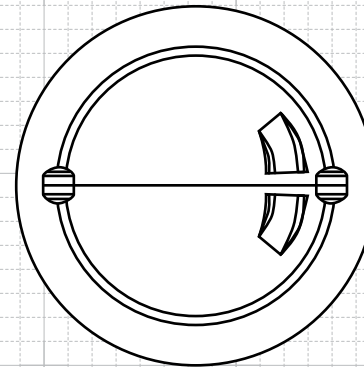

### BOTTOM VIEW

Recommended Plugs for this bottle



### FRICITION FIT

# PRINTING SPECIFICATIONS: 5 oz Sleek Cylinder 24/410

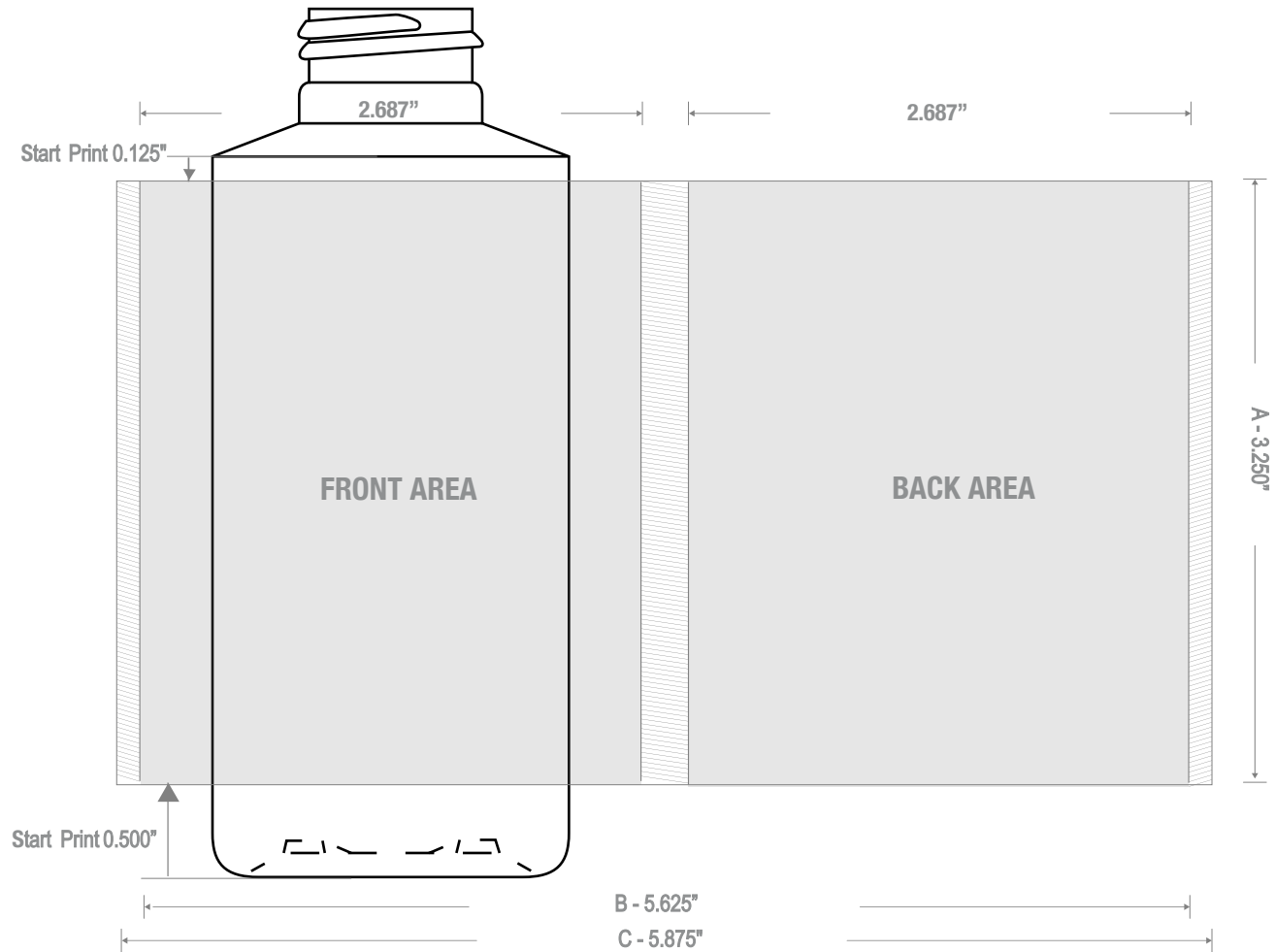

1700 S Hellman Ave, Ontario, California 91761  
 Phone: (909) 930-3610 | Fax: (909) 930-3640  
 e-mail: [info@classiccontainers.com](mailto:info@classiccontainers.com)  
[www.classiccontainers.com](http://www.classiccontainers.com)

**A - Total Height.**  
**B - Max. Decorating Area.**  
**C - Total bottle circumference.**  
 [Hatched Box] - Unprintable area.