

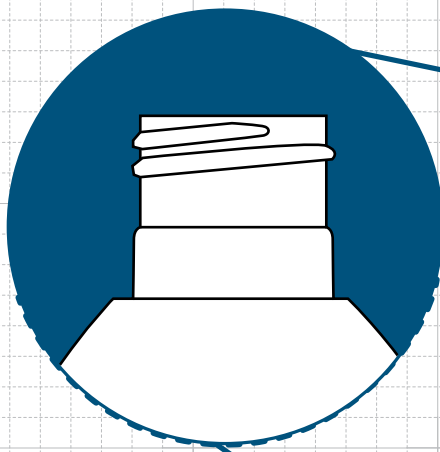

FRONT VIEW

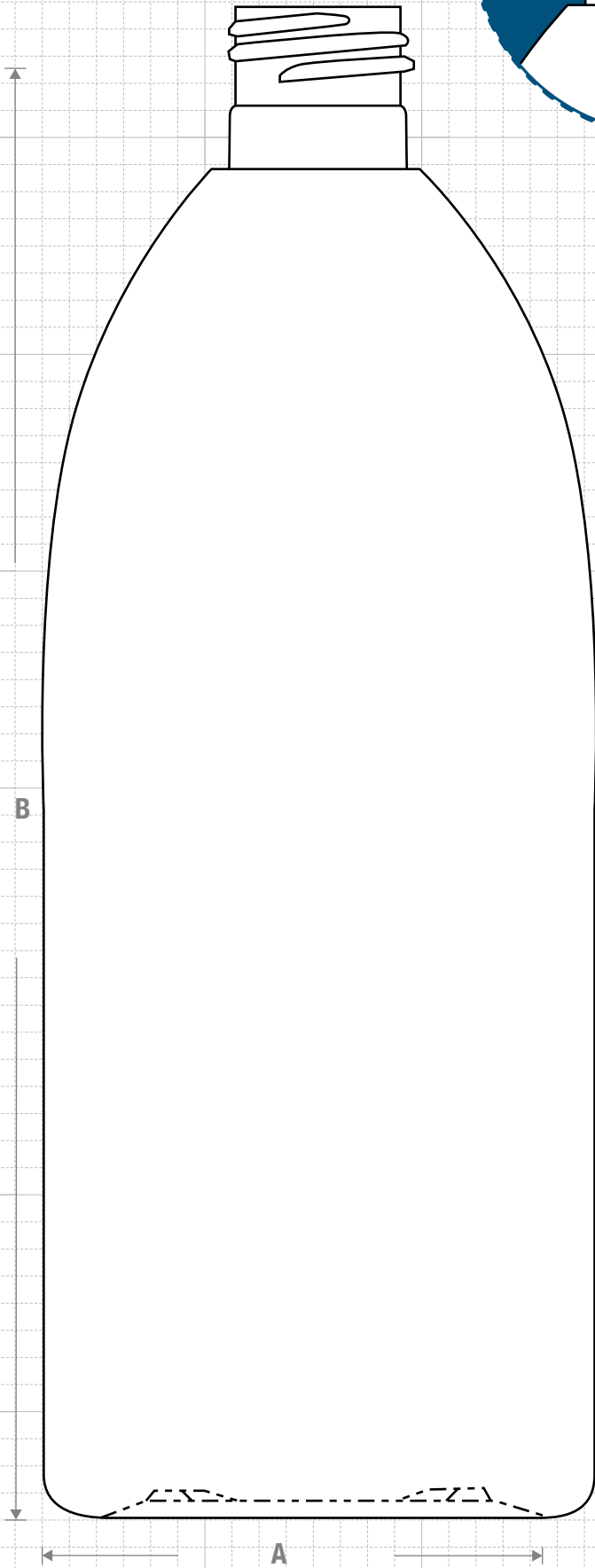

NECK & THREAD DETAIL

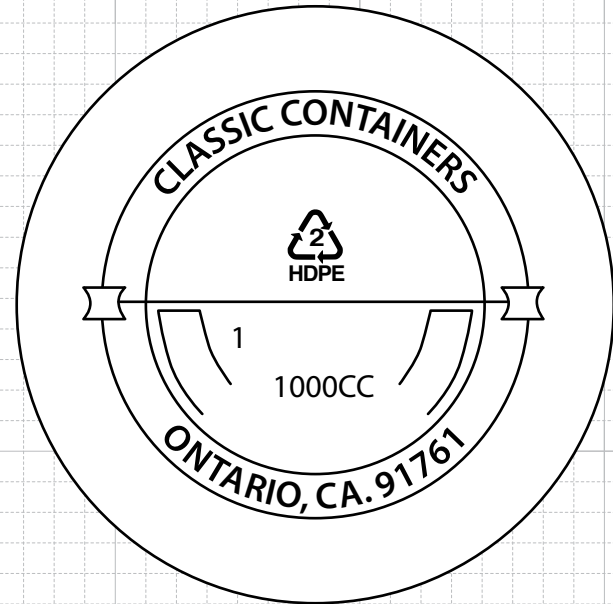
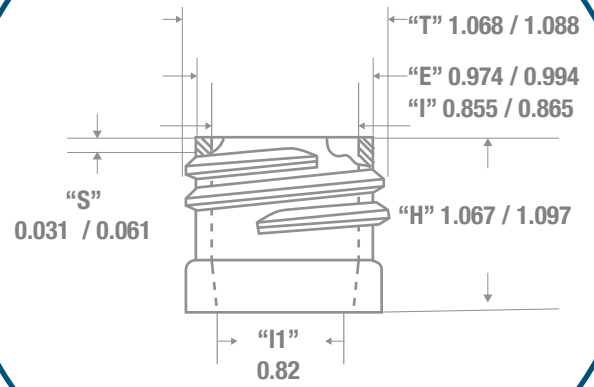

BOTTOM VIEW



CLASSIC CONTAINERS INC
1700 S. Hellman Ave.
Ontario, CA 91761
Phone: 909-930-3610
e-mail: info@classiccontainers.com
www.classiccontainers.com

Drawing:
32 oz Evolution 28/415

Gram Weight:
60 ± 2

Max Print Area (Height):
5.375"

Cases Per Pallet: **16**

Stock Code:
003200330290000

Neck Finish:
28/415

Max Print Area (Width):
10.250"

Box Dimensions:
24 7/16 x 18 1/2 x 23

Manufacturing Process:
Extrusion Blow Molding

Base Width (A):
3.350 ± 0.050

Case Pack: **94**

Stock Material:



Overflow Capacity:
1070 - 1100 ml (36.3 - 37.3 oz)

Overall Height (B):
10.054 ± 0.050

Case Weight (lb): **15.3 ± 0.4**

Rev #3 01/2016

Drawing not exactly to size.



A - 5.500"

B 10.250"



1700 S Hellman Ave, Ontario, California 91761
Phone: (909) 930-3610 | Fax: (909) 930-3640
e-mail: info@classiccontainers.com
www.classiccontainers.com

A - Total Height.
B - Total bottle circumference.