

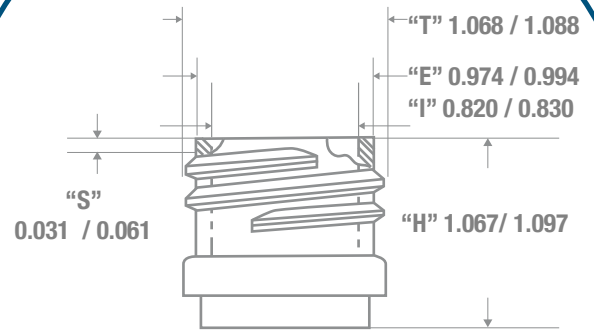

NECK & THREAD DETAIL

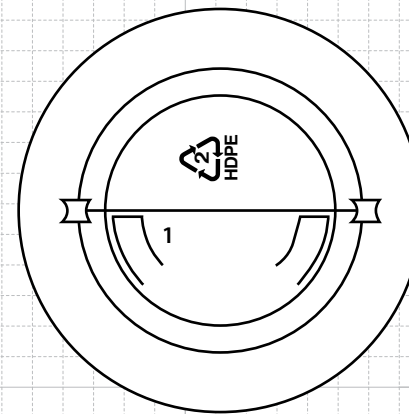

FRONT VIEW

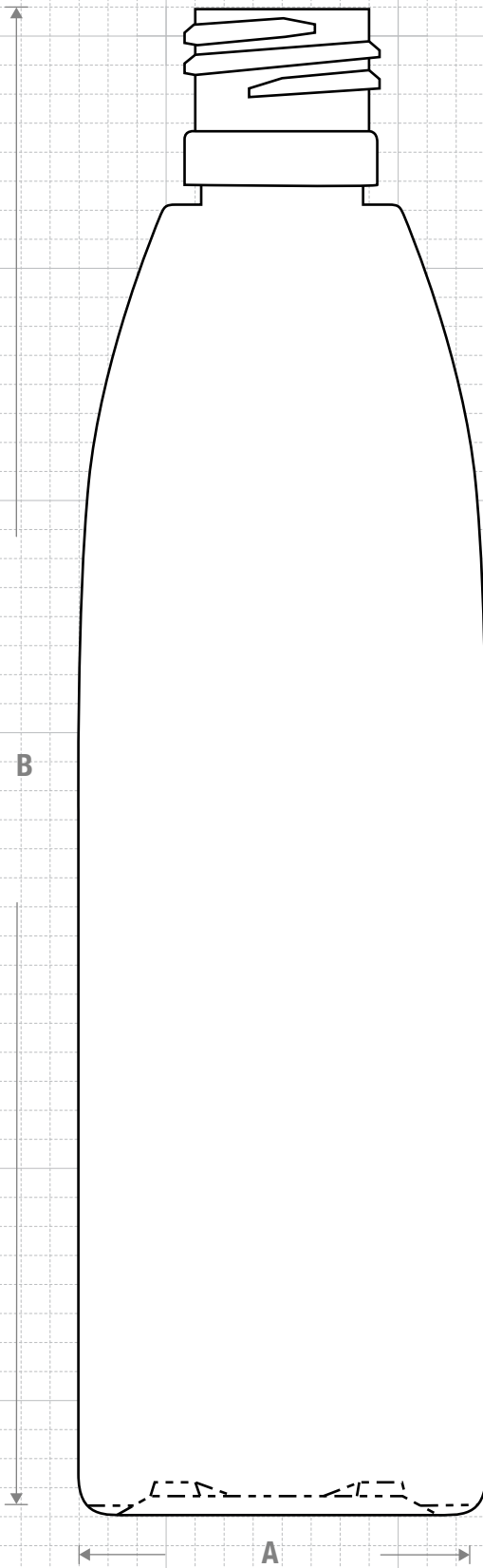

BOTTOM VIEW



CLASSIC CONTAINERS INC
 1700 S. Hellman Ave.
 Ontario, CA 91761
 Phone: 909-930-3610
 e-mail: info@classiccontainers.com
 www.classiccontainers.com

Drawing:
12 oz Evolution 28/415

Gram Weight:
30 ± 2

Max Print Area (Height):
5.000"

Cases Per Pallet: **16**

Stock Code:
001200330290000

Neck Finish:
28/415

Max Print Area (Width):
6.625"

Box Dimensions:
24 7/16 x 18 1/2 x 23

Manufacturing Process:
Extrusion Blow Molding

Base Width (A):
2.187 ± 0.050

Case Pack: **263**

Stock Material:



Overflow Capacity:
375 - 392 ml (12.7 - 13.3 oz)

Overall Height (B):
8.286 ± 0.050

Case Weight (lb): **20.3 ± 1.2**

Rev #1 09/2016

Drawing not exactly to size.



1700 S Hellman Ave, Ontario, California 91761
Phone: (909) 930-3610 | Fax: (909) 930-3640
e-mail: info@classiccontainers.com
www.classiccontainers.com

A - Total Height.
B - Total bottle circumference.

